



iSurfa-520 Surface Roughness Tester

Instruction Manual



Anhui Mikrosize Precision Instrument Co.,Ltd

Add: A-4035 RuiFeng Business Expo, Wuhu City, China, 241000.

Web: www.mikrosize.com **Email:** mikrosize@mikrosize.com

Contents

1.Brief Introduction.....	1
2.Measuring Operation.....	7
3.Options And Usage	20
4.Technical Parameter	25
5.General Maintenance	26
6.References.....	28
7.Packing List	35

1. Brief Introduction

The surface roughness measuring instrument is a hand-held instrument suitable for the production site environment and mobile measurement needs. It can measure the surface roughness of various machined parts. It can calculate the corresponding parameters according to the selected measurement conditions and display them on the display. All measured parameters and profile graphics are displayed on the screen. The instrument is easy to operate, comprehensive in function, fast in measurement, stable in accuracy, easy to carry, and can measure the main parameters of the latest international standards. This instrument fully and strictly implements international standards. The measurement parameters conform to the national standard of GB/T 3505 "Technical Specifications for Product Geometry, Surface Structure, Profile Method, Terms, Definitions and Parameters of Surface Structure" and are compatible with the standards of the United States, Germany, Japan, the United Kingdom and other countries. It is suitable for testing in workshop verification stations, laboratories, measurement rooms and other environments.

1.1 Features of Instrument

- Composite structure of main display unit, driver unit and Sensor. Electromechanical integration;
- DSP chip control and data processing, high speed, low power consumption;
- 14 parameters: Ra、Rq、Rz、Rt、Rp、Rv、R3z、R3y、Rz(JIS)、Rs、Rsk、Rku、Rsm、Rmr;
- 160μm large measurement range;
- 480*320 TFT color display, digital or graphic highlight display; no viewing angle;
- Display full information, intuitive and graphical displays all parameters;
- Compatible with ISO, DIN, ANSI, JIS multiple national standards;
- Built-in 6000mAh lithium-ion rechargeable battery and control circuit, high capacity, no

1. Brief Introduction

memory effect;

- There are remaining charge indicator, charging hint;
- Tester has charging instructions, the operator can readily understand the level of charge;
- Can work more than 20 hours while the power is enough;
- Large capacity data storage, can store 100 item of raw data and waveform;
- Real-time clock setting and display for easy data recording and storage;
- With automatic sleep, automatic shutdown power-saving features;
- Reliable circuit and software design of prevent the motor stuck;
- Instrument can display a variety of information tips and instructions. For example ;
Measurement result display, the menu prompts and error messages;
- Ergonomic housing design, rugged, compact, portable, high reliability;
- English / Chinese optional;
- Can connected to the computer and printer;
- All parameters can be printed or print any of the parameters which set by the user;
- Optional curved surface pickup sensor, holes sensor, minuteness holes sensor, measurement stand, Sheath of sensor, extension rod, printer and analysis software.

1.2 Measurement Principle

When measuring roughness of part surface, the pickup is placed on the surface of the part and then tracing the surface at constant rate. The pickup acquires the surface roughness by the sharp stylus in pickup. The roughness causes displacement of pickup which results in change of inductive value of induction coils thus generate analogue signal which is in proportion to surface roughness at output end of phase-sensitive rectifier. This signal enters data collection system after amplification and level conversion. After that, those collected data are processed with digital filtering and parameter calculation

1. Brief Introduction

by DSP chip and the measuring result can be read on OLED, printed through printer and communicated with PC.

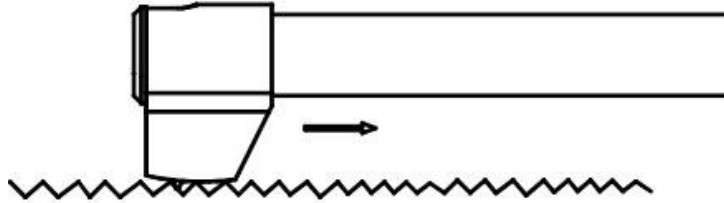

1.3 Name of Each part

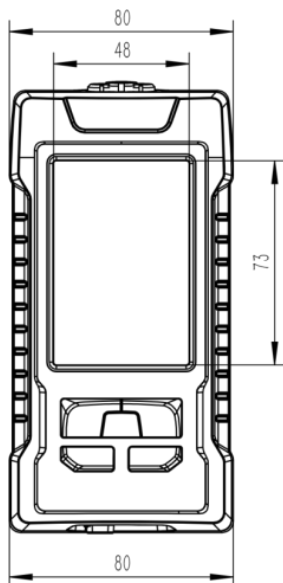
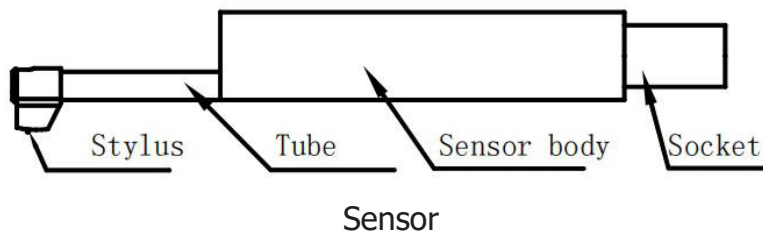

Instrument front view

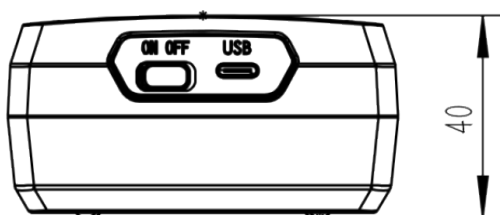
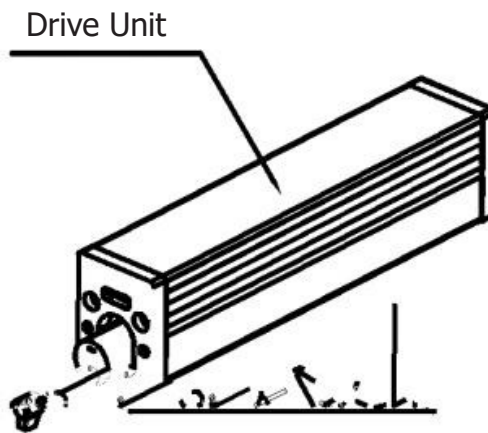

Instrument Back View

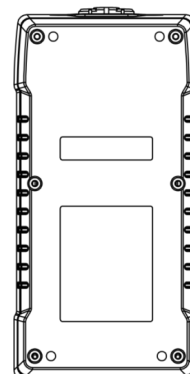

1. Brief Introduction

●Note: Power switch is a total power switch on the instrument. Turned off when not in use for a long time.

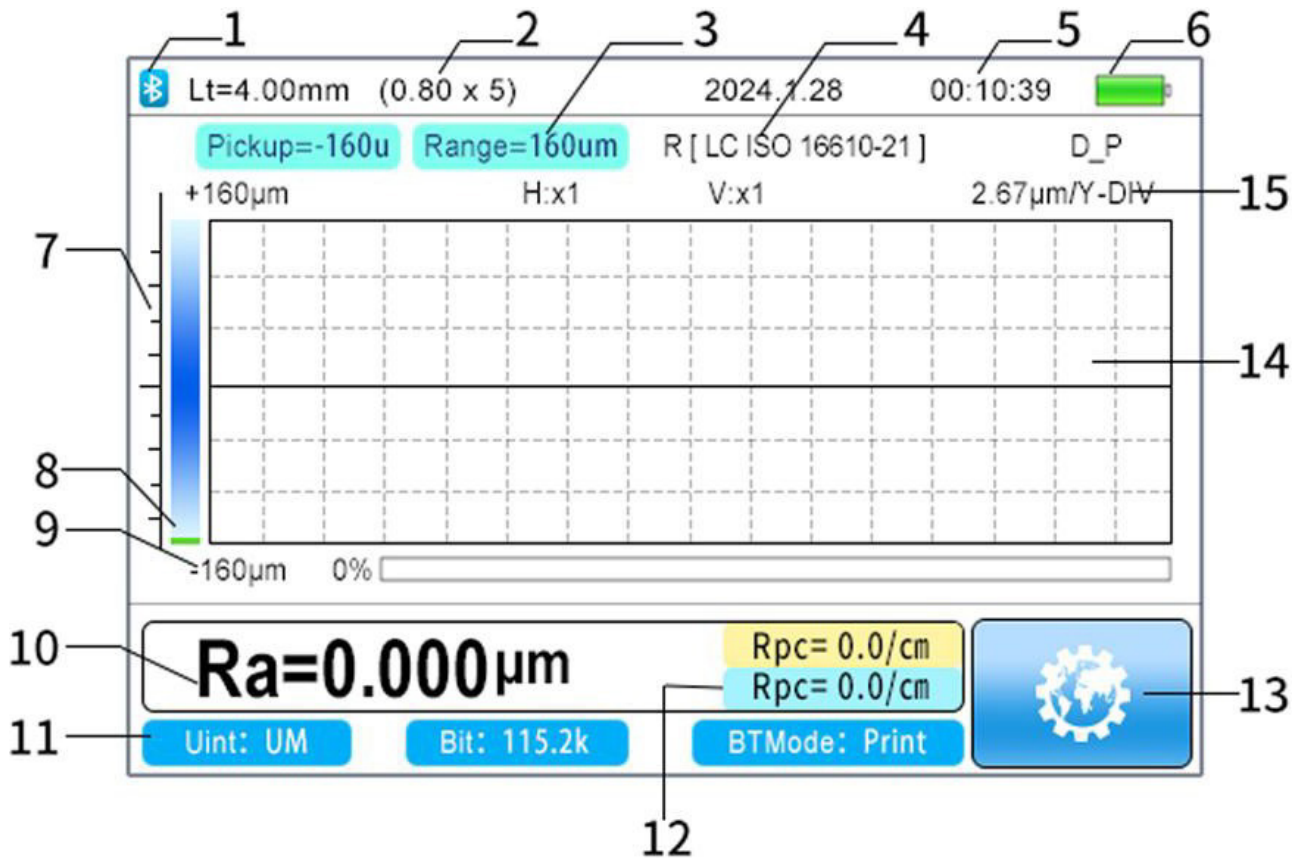

1. Bluetooth Mark

2. Sampling Length

3. Filter Type

4. Standards

5. Time

6. Battery Indicator

7. Prompt information

8. Measuring Tips

9. Range

10. Main parameter display area

11. Unit

12. Auxiliary display

13. Menu

14. Waveform Display

15. DIV

1. Brief Introduction

1.4 Buttons Define



Power key: Press and hold 2 seconds On/Off tester

START

Start key: For Start the instrument to measuring



Enter key: To enter the menu settings

ESC

Exit key: Used to exit the menu and unset



Record storage key: For store record results

Touch key of Hidden

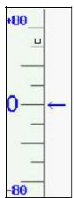

Start Touch Key

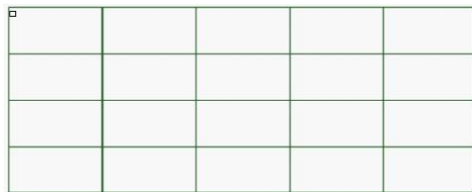

Profile Zoom Touch Key

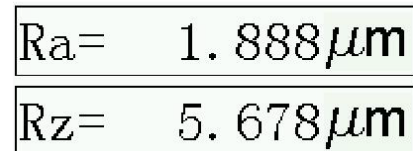

Multi Results and Profile Touch Key

1.5 Battery Charging

When battery voltage is too low (that is, battery voltage symbol display on screen to prompt low voltage), the instrument should be charged as soon as possible. USB port of the instrument for charging. You can use the built-in power adapter for charging, you can also use computer's USB port for charging. If use the other power adapter for charging, the output voltage should be 5V DC , the current should be greater than 800mA.

Instrument displays charging animation when charging after full animation ends, the display is full of symbols. Charging time of 2.5 hours.

This instrument adopts lithium ion chargeable battery without memory effect and charging can be fulfilled at any time without affecting normal operation of the instrument.

●Note:When charging, ensure that the instrument side of the power switch is in the ON position.

1. Brief Introduction

1.6 Connection Method of Sensor and Main Unit

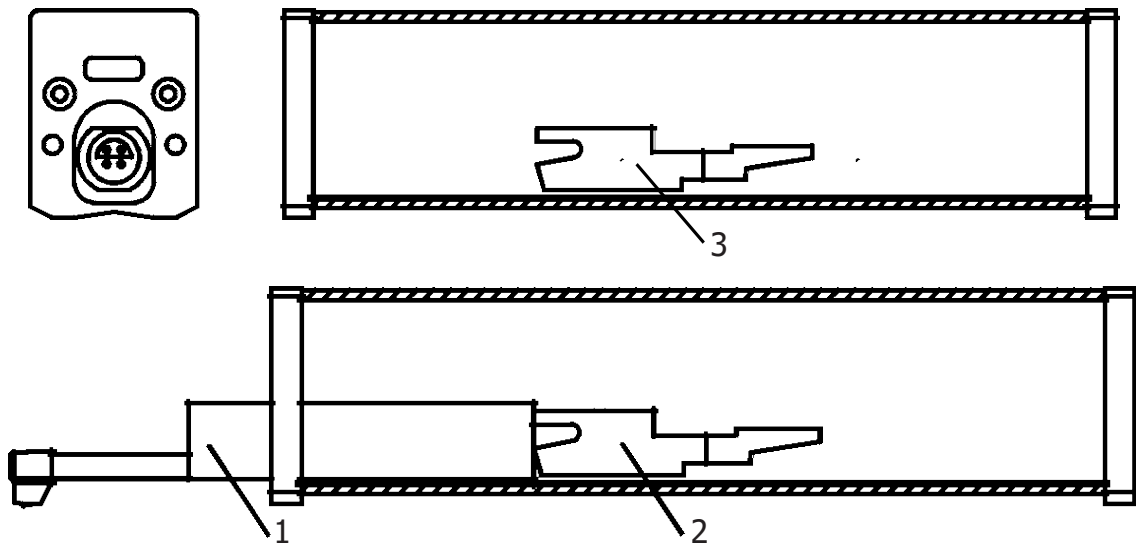

1.Sensor	2.Socket of drive unit	3.Drive unit
----------	------------------------	--------------

For installation, hold the main body of sensor with hand, push it into connection adapter at the bottom of the instrument as shown in Figure and then slightly pushed it to the end of the sheath. To remove, hold the main body of pickup or the root of protective sheath with hand and slowly pull it out.

Note:

- Stylus of pickup is key part of this tester and great attention should be paid to it.
- During installation and unloading, the stylus should not be touched in order to avoid damage and affecting measurement.
- Connection of sensor should be reliable during installation.

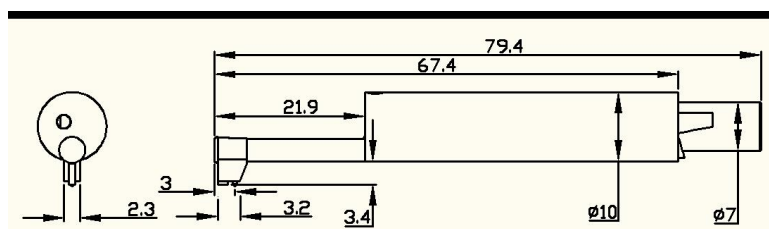
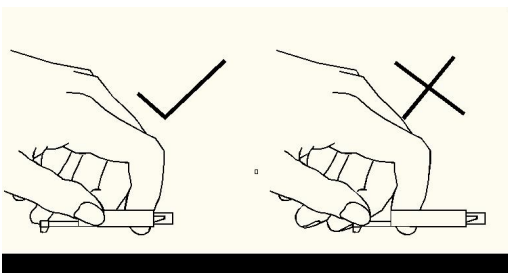

1. Brief Introduction

1.7 Connection method of Drive unit and Main Display unit

Please use an extension cable to connect the host and driver as shown in the figure below before use.



2. Measuring Operation

2.1 Preparation for Measurement

Switch-on to check if battery voltage is normal;

Clear the surface of part to be measured;

Place the instrument correctly, stably and reliably on the surface to be measured;

Trace of the pickup must be vertical to the direction of process line of the measured surface.



2.Measuring Operation



Correct and standard operation is the premise for accurate measurement result, please make sure to follow it.

2.2Turning On/Off

Press the key  to hold 2 seconds after the instrument will automatically boot, boot will display equipment type, name and manufacturer information, and then enter the basic measurement status main display interface, as shown.

Introductions:

- 1.The next boot will be displayed when the last shutdown set content;
- 2.Startup and shutdown, press and hold the key for about 2 seconds to open the instrument will perform the appropriate action;
- 3.Long time not to use, the instrument should be on the side of the power switch turned off;
- 4.Start measuring sensor is installed, please refer to the stylus position, try to adjust the stylus cursor position to the best position "0".

2.3Stylus Position

First, use the stylus position to determine the location of the sensor. The stylus as measured in the middle position.

Arrow indicates if it is not at zero point. The instrument can also be measured normally.

As long as the entire measurement process does not exceed the set range, it will not affect the measurement results.

2.4Start Measurement

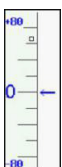

In the main interface mode, press the Start button to start measuring Press the Start key or Start key touch area to start measuring

The measurement can be stopped according to ESC

2.Measuring Operation

2.5 Measurement Result Display

After the measurement, if you need to look at all the measurement results, touch the main and secondary display area will be able to see all the calculation results. The touch profile display area will zoom the profile by 1-2-4-8.

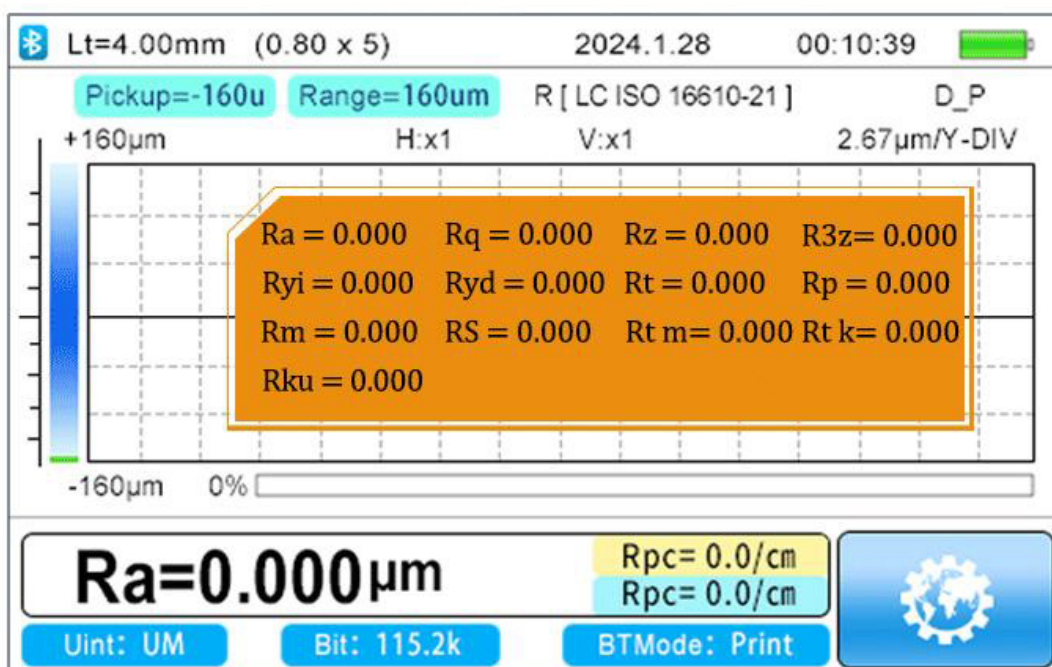
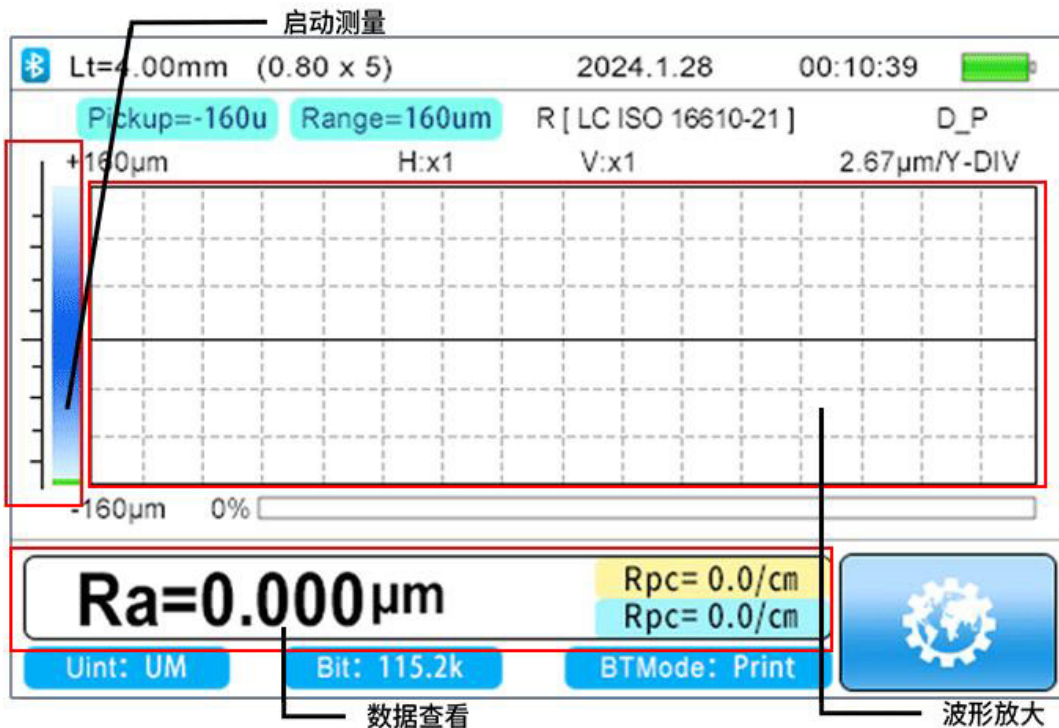

2.Measuring Operation

2.6Print Measurement Results

The instrument can be connected to the printer. The measurement results will be printed.

After measurement, Press  key to display the measurement results.

The instrument can be tested according to the actual requirements of arbitrary parameters choose to print or print all the parameters, how to set the parameters, refer to "Print Settings."

2.7Storage Measurement Results

In the main display interface mode, press the  key to save the measurement results stored in the instrument memory. Instrument built-in large capacity memory, can store 100 groups of raw data and waveform data.

Data storage recording date and time the file name automatically generated according to the last data record is always stored the most recent recording time, the last data record stored recording record number will be 001.

2.8Measuring Parameter Settings

In the basic measurement mode, press the  key to enter the menu operation state.

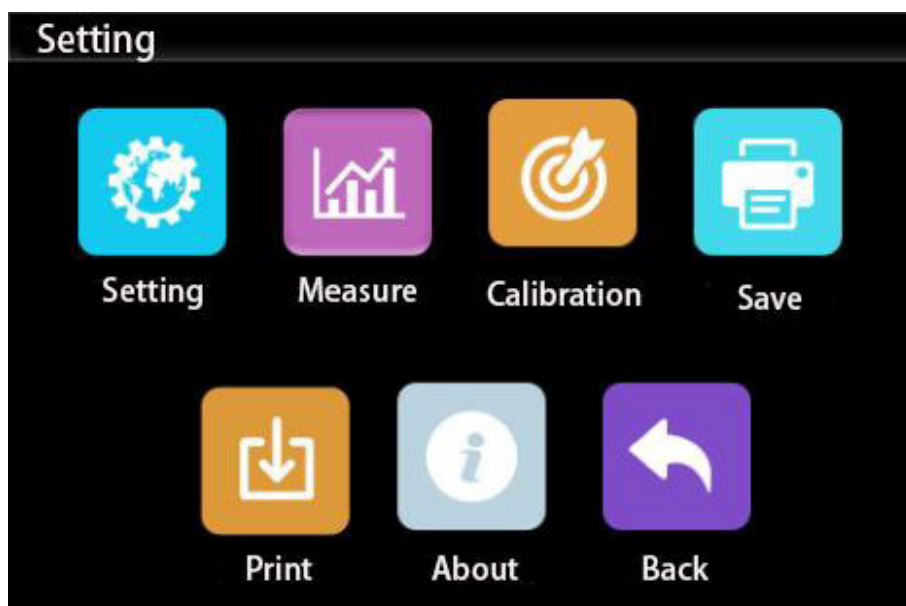

2.Measuring Operation

2.9Setting

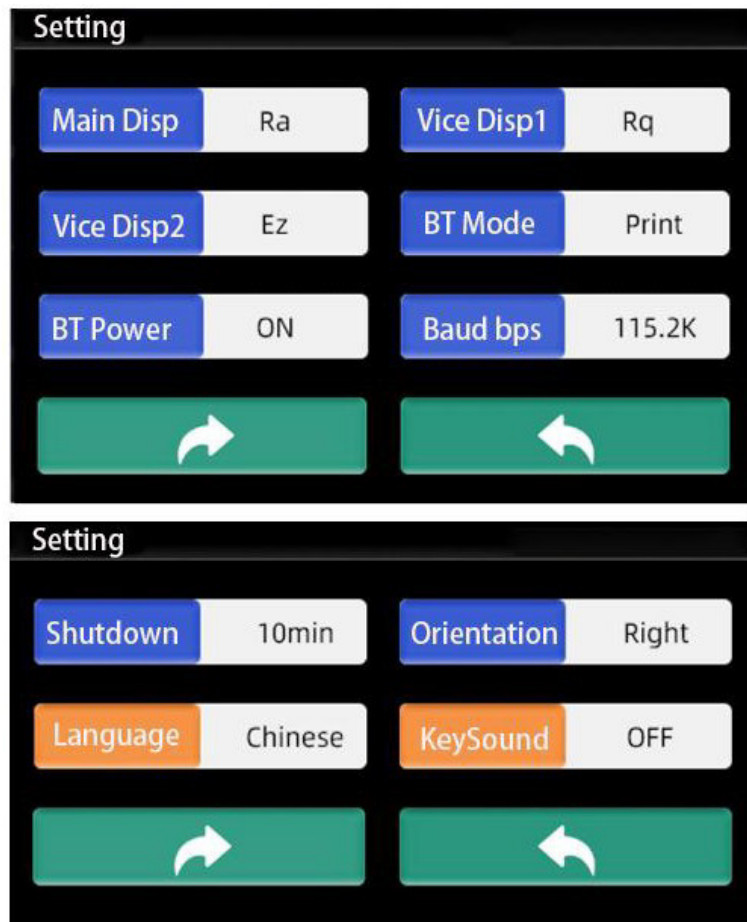

2.9.1Main display parameters and auxiliary display parameters

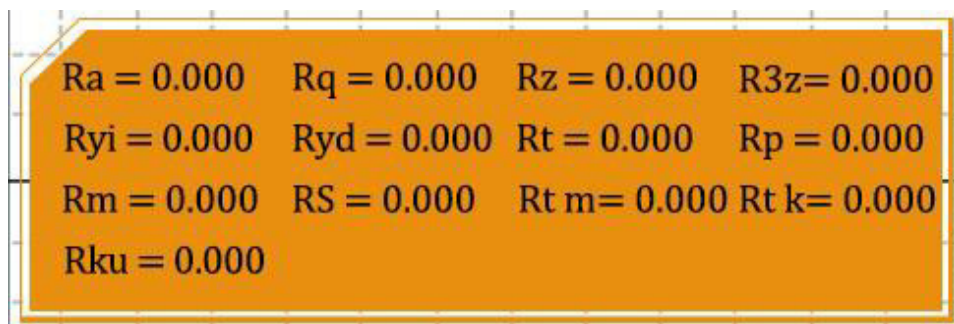

2.9.2BPS rate setting

The BPS rate of communication between instrument and printer or between instrument and APP of mobile phone.

Default BPS rate 115.2K

2.Measuring Operation

2.9.3Auto shutdown

Set to ON instrument for 600 seconds without operation will be automatically shutdown .

When OFF is set, it will work all the time

2.9.4Bluetooth mode

There are 2 mode to operate Bluetooth module, print mode and data transmission mode.

Set it to print when Bluetooth printing is needed and to Ctrl when communicating with mobile APP

Bluetooth switch can only be operated when Bluetooth power is off.

2.9.5Bluetooth Power

Please set the Bluetooth mode first, then turn ON the Bluetooth power, the instrument will automatically set the Bluetooth module as required.

Because of the unnecessary battery capacity loss caused by the long-term opening of the Bluetooth function, the instrument will turn off the Bluetooth power after each boot. If you need to use Bluetooth function, please open it yourself.

2.9.6Rpc Details settings

According to user's demand, Rpc-parameter's calculation can be selected from " μm " and "%".

2.9.7Date and Time settings

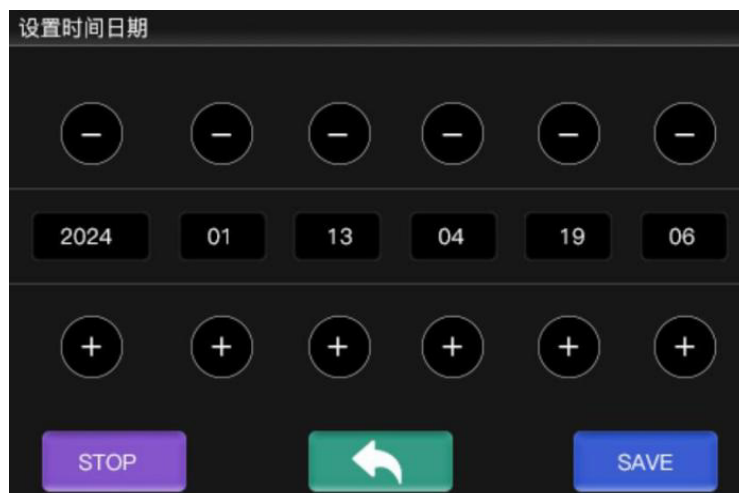

2.Measuring Operation

If you want to change the date and time, please press STOP first, after the modification is finished, press START.

2.9.8LCD Display brightness settings

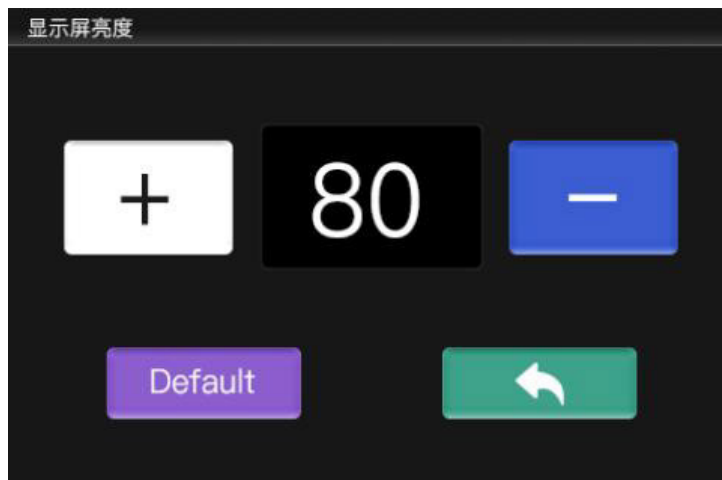

2.9.9Reset factory settings

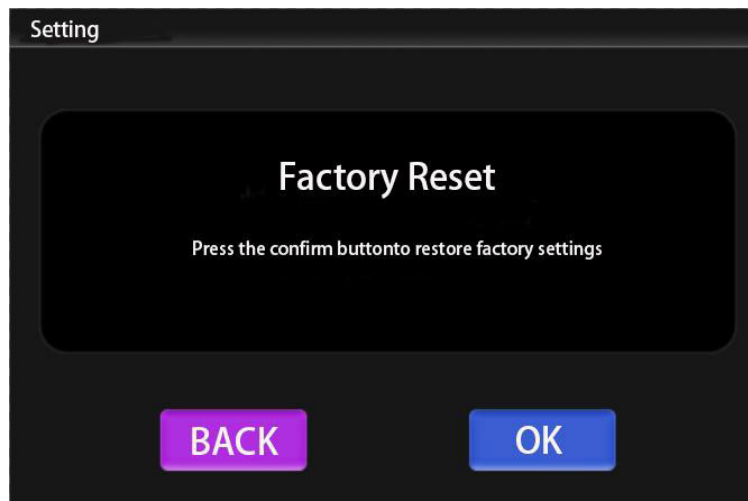

2.9.10Format memory

Data formatting is the deletion of data records. Once formatted, all data will be emptied. Before the data formatting, the instrument has the confirmation prompt information. After the user confirms, the data will not be restored. Please proceed with caution.

Format memory takes about 1 minutes, please do not turn off the power.

2.Measuring Operation

2.10 Measuring Condition Settings

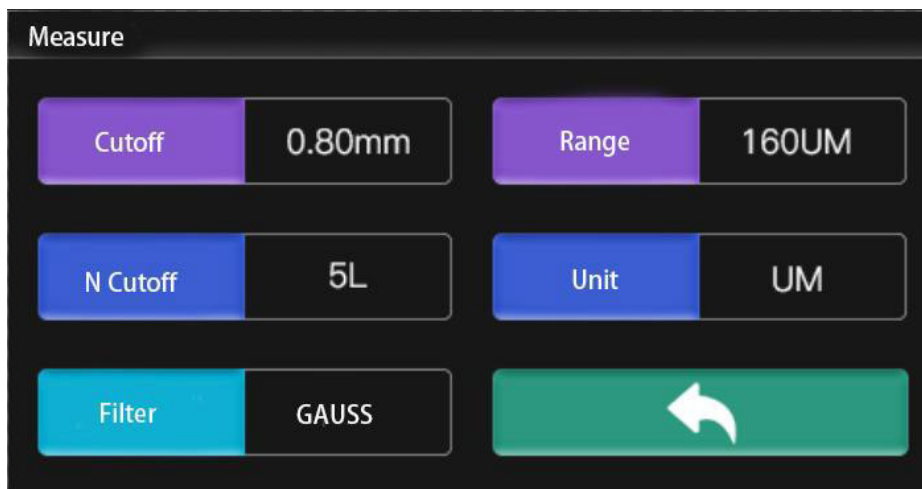

Cut off length λ_c	0.25mm;0.80mm;2.50mm
Number of Sampling lengths ($\times n$)	1-5
Range	$\pm 20\mu\text{m}$; $\pm 40\mu\text{m}$; $\pm 80\mu\text{m}$; $\pm 160\mu\text{m}$
Unit	Inch;mm
Filter	RC;PC-RC;GUASS;D-P

The required parameters should be set before measurement, and the sampling length, evaluation length, range selection, and filter should be set according to the specific conditions of the workpiece.

Selection principle:

- 1.Refer to 6.3 Introduction for the recommended sampling length value table
- 2.The evaluation length first selects the standard recommended value, $l_n=5l$, that is, the evaluation length includes 5 sampling lengths. When the size space of the surface to be measured of the workpiece is less than 7 sampling lengths (2 sampling lengths are used for calculation and filtering), less than 5 sampling lengths can be selected, but it should be noted that the fewer the number of sampling lengths selected, the The worse the repeatability of the indication
- 3.For range selection, it is recommended to start with the minimum range. When an over-

2.Measuring Operation

range alarm occurs, increase the range.

4. There are 4 filtering methods in this instrument:

RC: traditional filter, Commonly seen on older analog instruments, now often implemented with digital filtering. The characteristic is that the shape of the contour after filtering is distorted, which has little effect on the Ra parameter value, but has different degrees of influence on other parameters.

PC-RC: The RC is phase corrected, and the shape of the contour is basically unchanged after filtering. Its amplitude transfer characteristics are the same as RC

Gauss: new standard filter, Will replace RC. The characteristic is that the shape of the contour after filtering is basically unchanged.

D-P: Take least squares median line only for unfiltered contours

2.11 Record Management

Click on the corresponding record to see the details of the record.



2.12 Software Information

Instruments software and hardware information can help users easily upgrade and maintain the product, unique serial number of the instrument software information items are displayed.

2.Measuring Operation

2.13Parameter Calibration

Before measuring instrument, usually required calibration use standard calibration. Block. The instrument is configured with a standard calibration block, before measurement, instruments to test the block. Under normal circumstances, when the measured value and the block value of the difference in the acceptable range, the measurement value is valid, can be measured directly.

If the measured value and the block value of the difference is greater than a accuracy error range of the instrument, or the user require high accuracy, can be used to correct the indication calibration function and improve measurement accuracy. Showing the value of the calibration procedure as shown.

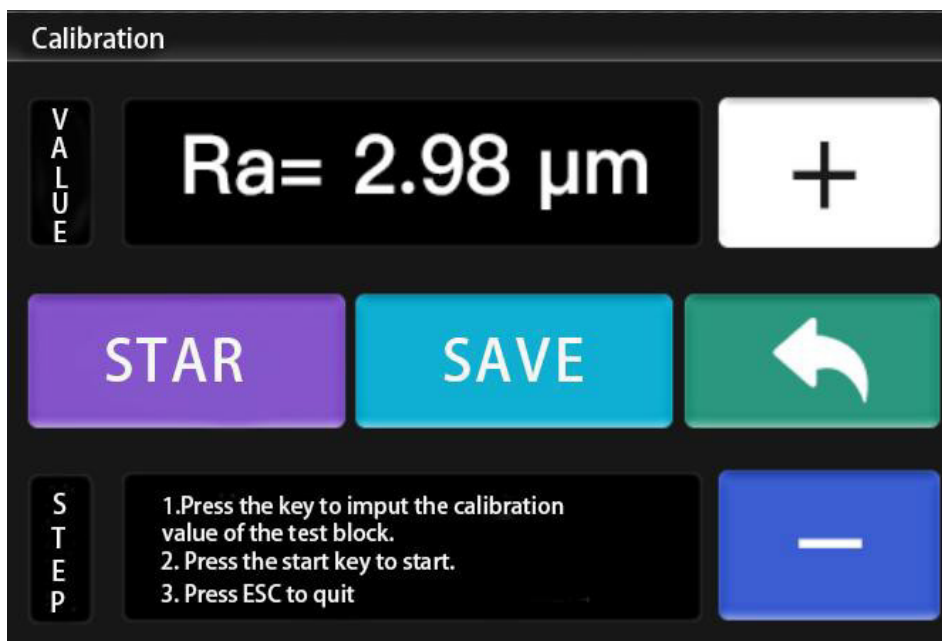

1. Under normal circumstances, the instrument in the factory have been rigorously tested, showing error is much less than $\pm 10\%$, in this case, the user is not showing the value of the calibration frequently used functions.

2. After setting the calibration value, you must press the "STAR" key for a full measurement, instrument calibration to be valid.

3. New parameters after calibration must be carried out once a complete measurement and

2.Measuring Operation

press the SAVE key is stored in the instrument.

4.Press "ESC"key to return the menu without saving calibration results.

2.14Print Function setup

The instrument can be tested according to the actual requirements of any parameter selection Print or Print All, the steps shown in Figure.

打印管理

NO.	Time	Parameter
1	12:14:25	0.000 0.000 0.000 0.000 0.000 0.000
2	12:14:27	0.000 0.000 0.000 0.000 0.000 0.000
3	12:14:29	0.000 0.000 0.000 0.000 0.000 0.000
4	12:14:31	0.000 0.000 0.000 0.000 0.000 0.000
5	12:14:40	0.000 0.000 0.000 0.000 0.000 0.000
6	12:14:42	0.000 0.000 0.000 0.000 0.000 0.000
7	12:14:44	0.000 0.000 0.000 0.000 0.000 0.000

Navigation icons: Down arrow, Up arrow, Left arrow, Ra, Print icon.

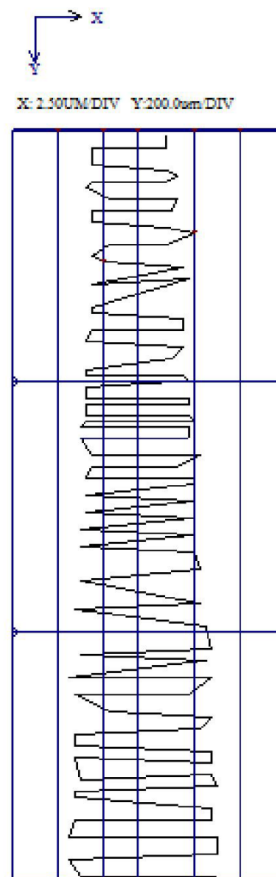
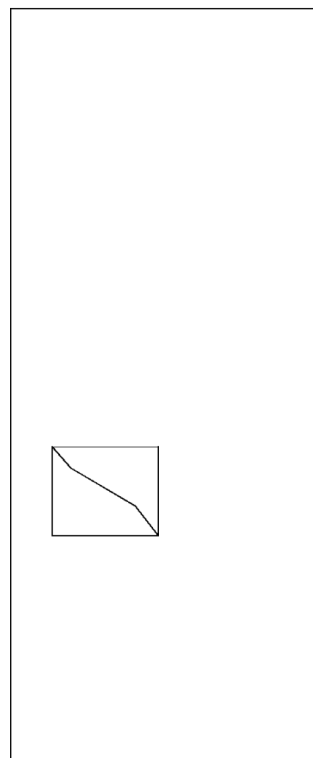

2.Measuring Operation

Report					
Ra=1.466μm	Rq=1.538μm	Rz=3.412μm	R3z=3.412μm	Ryi=3.448μm	Ryd=3.486μm
Rt=3.510μm	Rp=2.146μm	Rm=1.302μm	RS=0.070mm	RSm=0.070mm	Rku=0.313

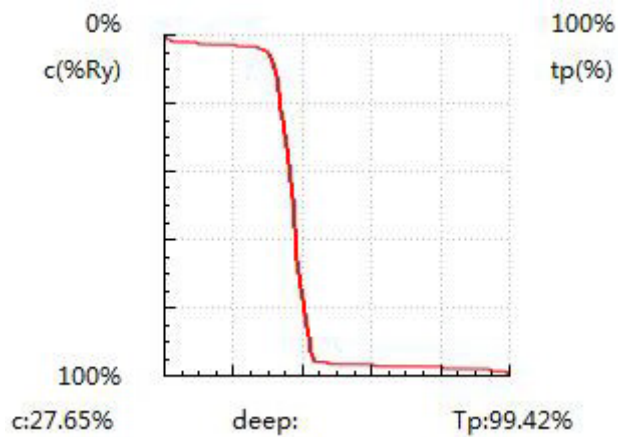
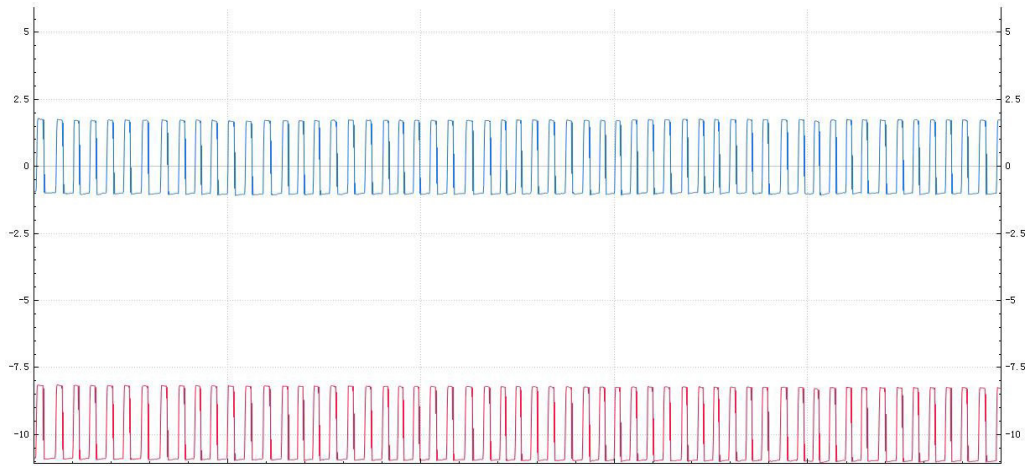

Unit setting:um	Sampling length:0.8mm	Rating length:5l
Standard:ISO	Range:±40μm	Filter:Gauss
Operator:1	Workpiece:1	Date:11.6

3.Options and Usage

3.1 Adjustable height support feet

When measured surface of part is smaller than the bottom surface of the instrument, sheath of pickup and adjustable supporter of instrument options can be used for auxiliary support to complete the measurement (as shown in Figure).

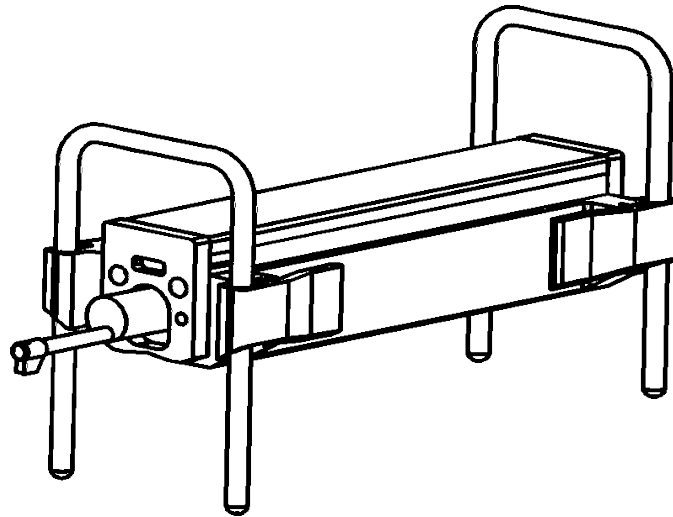

3.2 Table base connection block

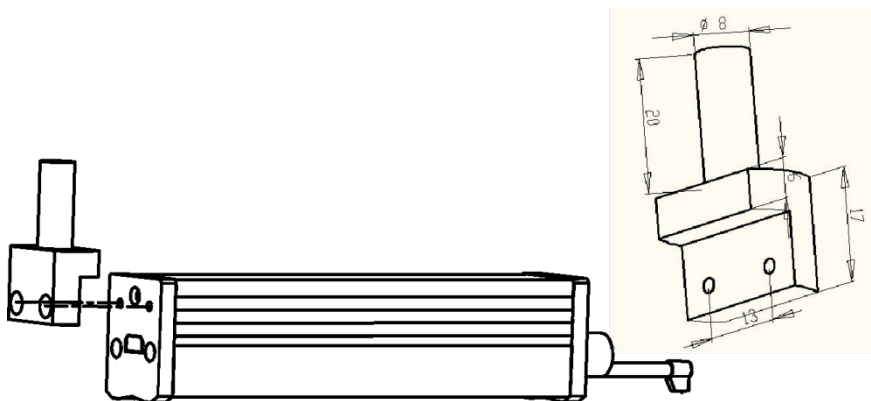

3.3 Measurement Stand

Measurement Stand can adjust the positions between tester and measured part conveniently with flexible and stable operation and wider application range. Roughness of complex shapes can also be measured. Measurement stand enable the adjustment of the position of stylus to be more precise and measurement to be more stable. If Ra value of measured surface is relatively low, Using measurement platform is recommended.

3.Options and Usage

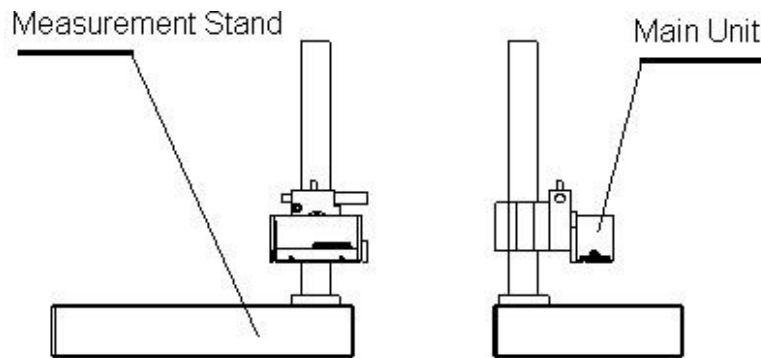

3.4 Extending Rod

Extending rod increases the depth for pickup to enter the part. Length of extending rod is 50mm.

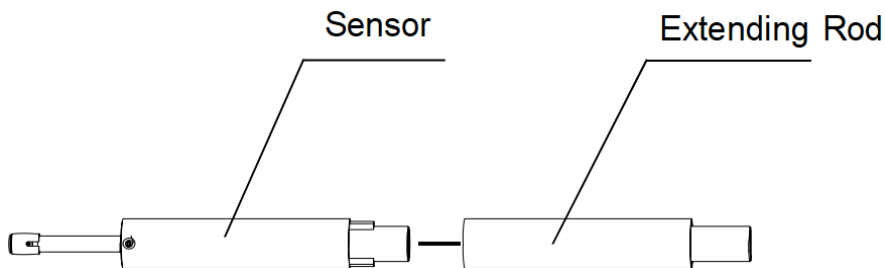

3.5 Small Hole Sensor

Most of the standard sensor sensor, it can measure most of the plane, inclined plane, cone surface, inner hole, groove and other surface roughness, can be hand-held measurement, in addition to the standard sensor, other special sensors are needed to measure the measuring platform.

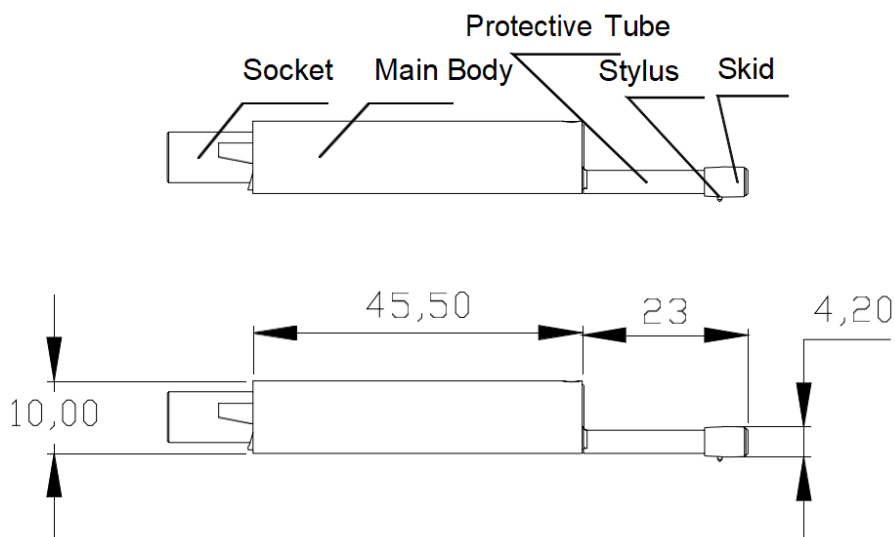

3.Options and Usage

3.6 Curved Surface Sensor

Curved surface sensor is mainly used for measuring radius is larger than the smooth cylindrical 3mm surface roughness, for the larger radius smooth spherical surface and other surface also can obtain good approximation, the radius of curvature, the surface is smooth, the better the effect of measurement.

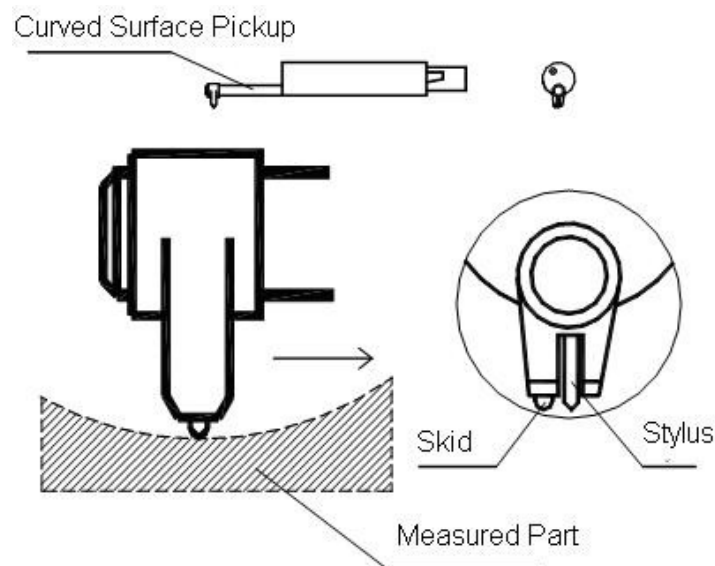

3.6.1 Curved surface sensor operation method

The main difference between the curved surface sensor and other sensors is that the skid and the stylus are parallel, and the other sensors are arranged in front and back.

The curved surface sensor must be installed on the measuring stand for measurement.

3.7 Pinhole Sensor

Using Pinhole pickup, the inner surfaces of holes with radius more than 2mm can be measured. Refer to the following Figure for detailed dimension.

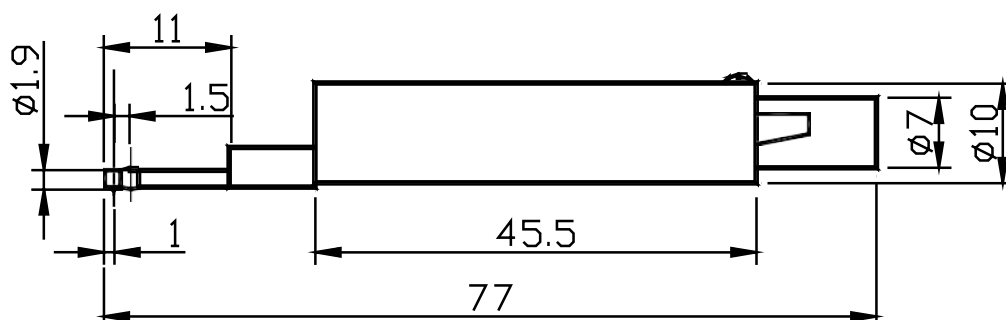

3.Options and Usage

3.7.1 Extra small hole sensor operation method

The skid of the extra small hole sensor is behind the stylus. When it contacts the workpiece, the pickup position is first high and then low.

The use of extra small hole sensors must be installed on the measuring stand for measurement.

3.8 Deep Groove Sensor

With deep groove sensor, it is possible to measure groove with width wider than 3mm and depth deeper than 10mm, or the surface roughness of step with height less than 10mm, Also can used to measure the planar, cylindrical used with platform. please see figure for detailed dimension.

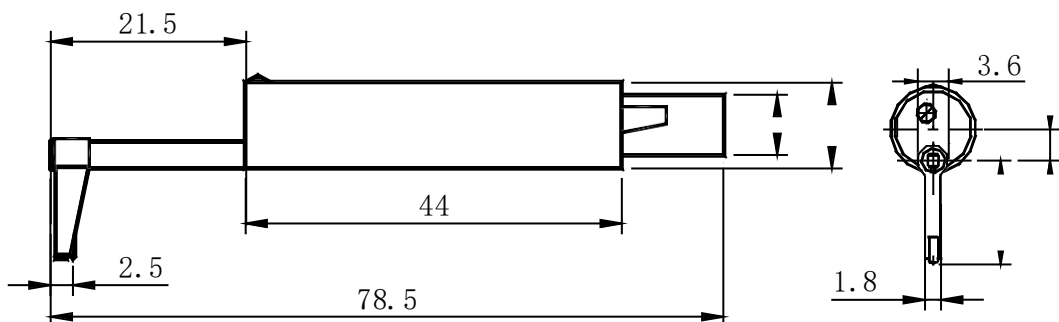

Deep groove sensor

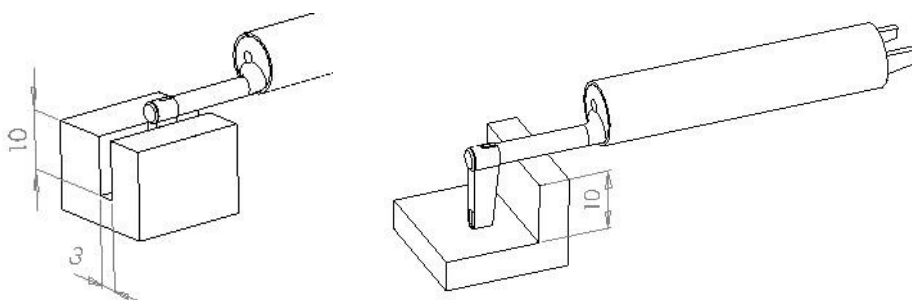

3.9 Nosepiece for flat surface

It is suitable for measuring the roughness of the measured object which is smaller than the roughness tester and the measuring plane is plane. The nosepiece can protect the sensor effectively

3.Options and Usage

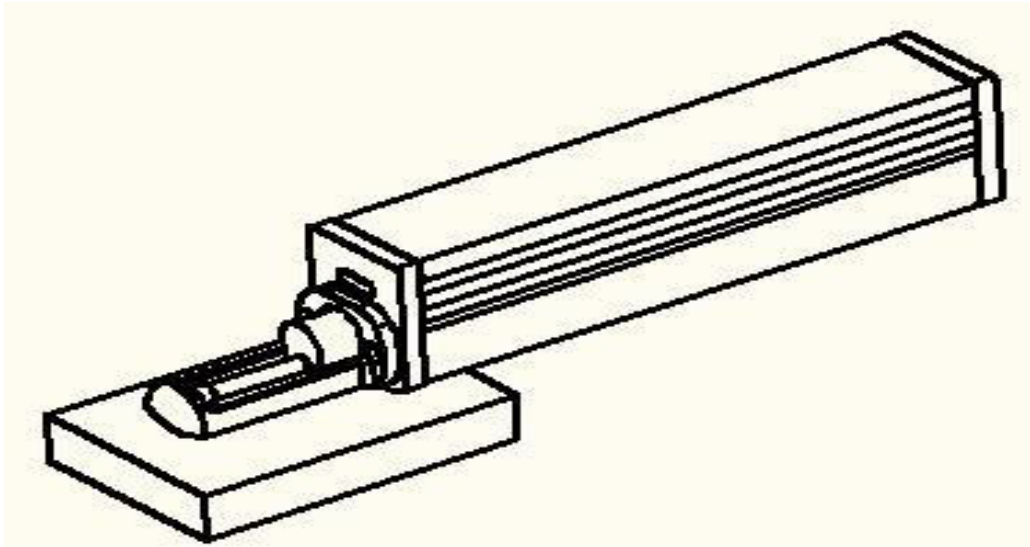

3.10 Nosepiece for cylindrical surface

It is suitable for measuring the roughness of cylindrical object which can not be measured directly. The nosepiece can protect the sensor effectively.

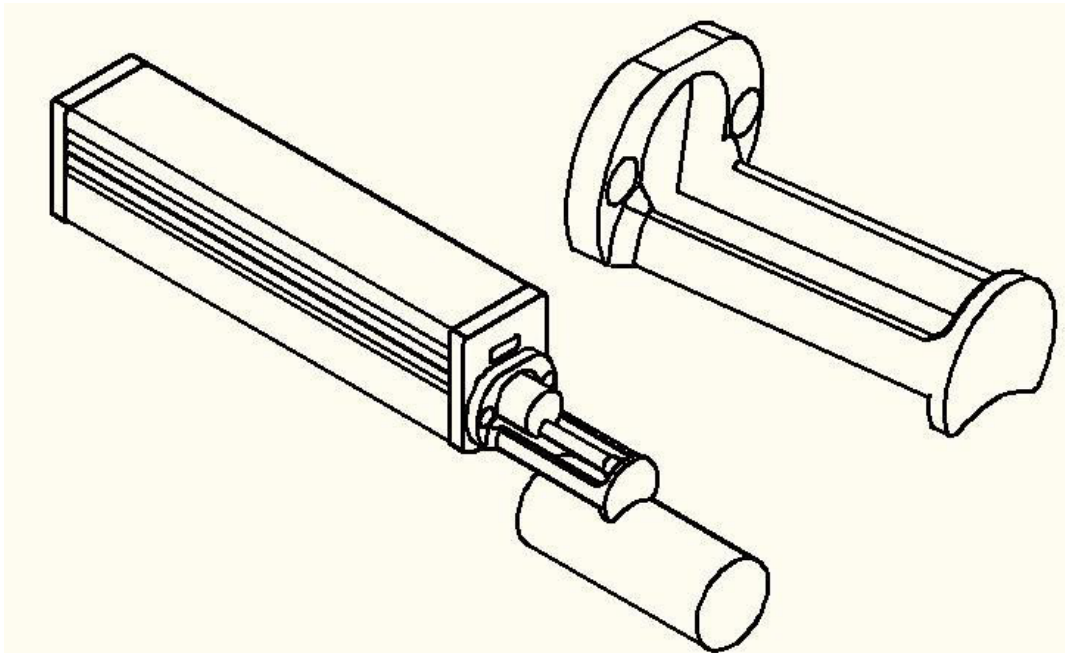

4. Technical Parameter

Name		Content	
Measurement Range	The Z axis (vertical)	320 μ m	
	The X axis (horizontal)	17.5mm/0.71"	
Resolution ratio	The Z axis (vertical)	0.01 μ m/ \pm 20 μ m	0.02 μ m/ \pm 40 μ m
		0.04 μ m/ \pm 80 μ m	
Measurement item	Parameter	Ra Rz Rq Rt Rc Rp Rv R3z R3y Rz(JIS) Ry Rs Rsk Rku Rmax Rsm Rmr R _{Pc} Rk Rpk Rvk Mr1 Mr2	
	Standard	ISO4287,ANSI B46.1,DIN4768,JISB601	
	Graphic	Primary profile, Roughness profile, load curves	
Filter		RC,PC-RC,Gauss,D-P	
The sampling length(lr)		0.25,0.8,2.5mm	
Assessment length(ln)		Ln= lr \times n n=1~5	
Sensor	Principle	The displacement differential inductance	
	Stylus	Natural Diamond, 60B cone angle, 2 μ m tip radius	
	Force	<4mN	
	Skid	Ruby,Longitudinal radius 40mm	
	Traversing speed	lr=0.25, Vt=0.135mm/s	
		lr=0.8, Vt=0.5mm/s	
		lr=2.5, Vt=1mm/s	
Return,Vt=1mm/s			
Accuracy		0.001 μ m	
Repeatability		No more than 10%	
Variability		No more than 6%	
Power supply		6000mAh Lithium ion battery,Charger :DC5V	
Size(L*W*H)	Display Unit	161*80*40mm	
	Drive Unit	22*26*114mm	
Weight		About 320g	
Working Environment		Temperature:- 20 $^{\circ}$ C ~ 40 $^{\circ}$ C Humidity:< 90% RH	
Store and Transportation		Temperature:- 40 $^{\circ}$ C ~60 $^{\circ}$ C Humidity:< 90% RH	

4.2 Measuring Range

Parameter	Measuring range
Ra Rq	0.005 μ m~16 μ m
Rz R3z Ry Rt Rp Rm	0.02 μ m~320 μ m
RSk	0~100%
RS,RSm	1mm
tp	0~100%

5. General Maintenance

5.1 Sensor

1. Any time swap sensors are to be especially careful, careful not to touch the guide head and a stylus, because this is a key part of the whole instrument, to try to hold the sensor guide head bracket roots (the front of the body) plug.
2. To complete the measurement work, please timely sensor into the box;
3. Please pay attention to protect the needle part measuring sensor.
4. The sensor's precision components, any knock, touch, fall off phenomenon may damage the sensor, should try to avoid such situations.
5. The sensor is a damageable parts, do not belong to the scope of warranty parts, only provide repair. In order not to affect the measurement work, users are advised to buy backup sensor used for emergency.

5.2 Main Unit

1. Pay attention to maintaining the Main Unit surface clean, often with a soft dry cloth to clean its surface.
2. The instrument is a precision measuring instrument, should always be handled with care, to avoid the shock.

5.3 Battery

1. Always observe the battery prompt, when the low voltage, please charge.
2. The charging time is 6 hours, try not to long time charge.

5.4 Standard Sample Plate

1. The surface of a standard sample plate must be kept clean.
2. To avoid scratches on the surface of sample area.

5.5 Troubleshooting

5. General Maintenance

When the tester breaks down, handle the troubles according to measures described on Fault Information. If troubles still exist, please return the instrument to JIMTEC for repair. Users should not dismantle and repair the device by themselves. Returned instrument should be accompanied with sample plate attached. Phenomenon of problem should be explained.

Error message	Cause	Solutions method
Motor error	Motor stuck	Reboot
Out of Range	1.The measured surface signal exceeding the measurement range 2.Placed away from the center of the stylus position	Increase Measuring range Adjust the Stylus position
No test data	After the boot does not measure.	The actual measurement: one time
Measurement Accuracy Out of Range	Set the parameter error Calibration data error	Set the parameter measurement Calibrate the tester

6. References

6.1 Terms

The instrument calculates parameters on the filter profile and the direct profile, all calculated in line with the GB / T 3505-2009 "Geometrical Product Specification(GPS) — Surface texture: Profile method—Term, definitions and surface texture parameters."

6.1.1 Terms

Filtered profile: profile signal after primary profile is filtered to remove waviness.

D-P (direct-profile): adopt central line of Least Square Algorithm.

RC filter: analogue 2RC filter with phase difference.

PC-RC filter: RC filter with phase-correction.

Gauss filter: ISO11562.

6.1.2 Traversing Length

•RC Filter

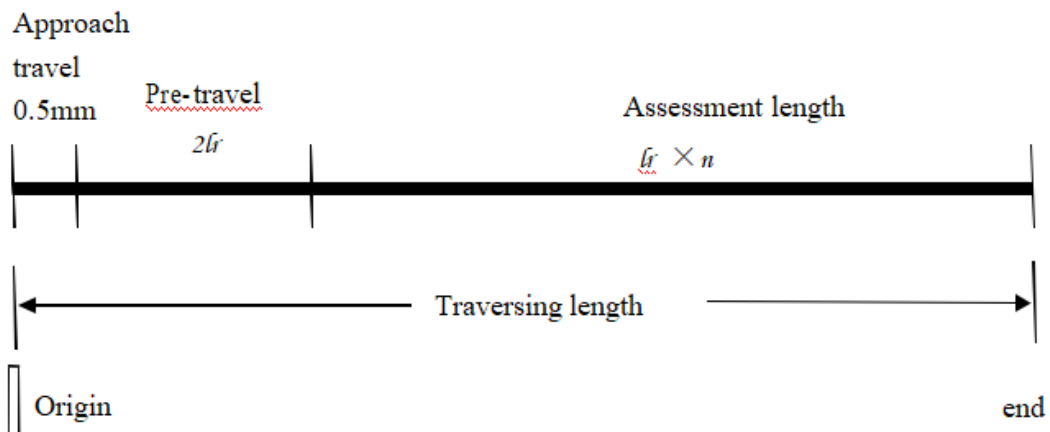

•GAUSS Filter

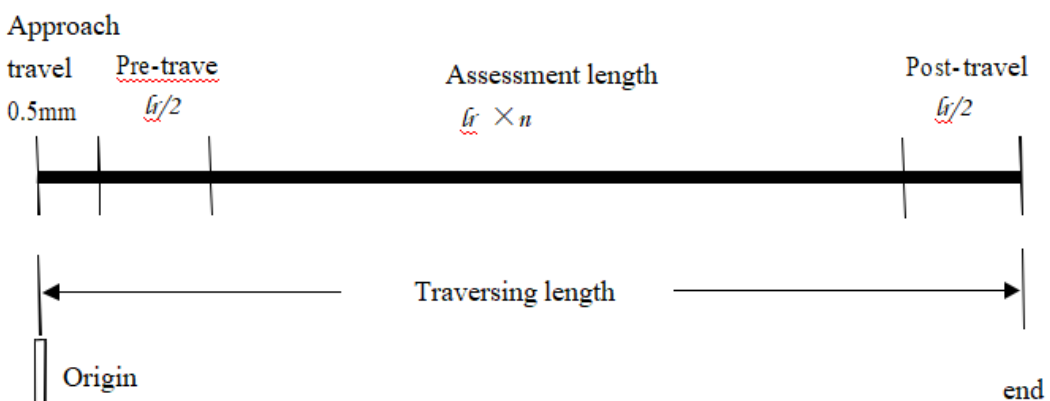

6. References

- PCRC Filter

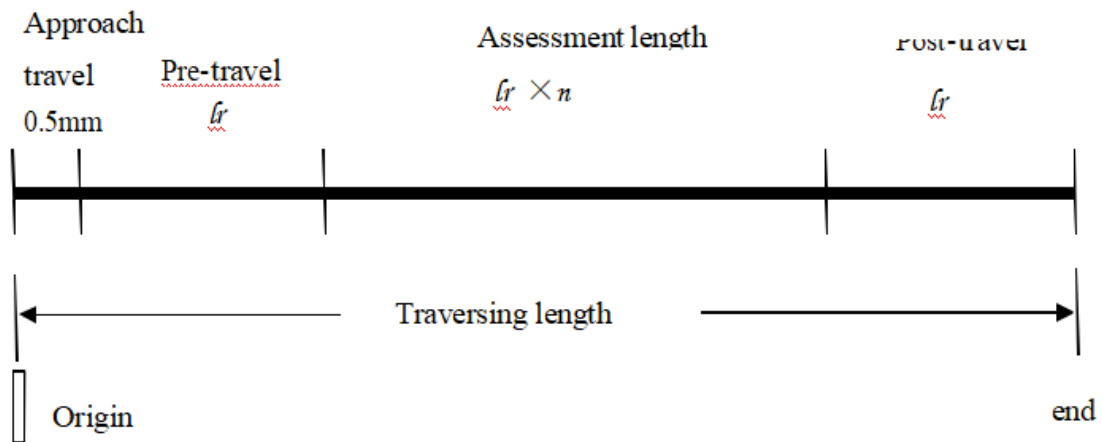

- D-P direct profile

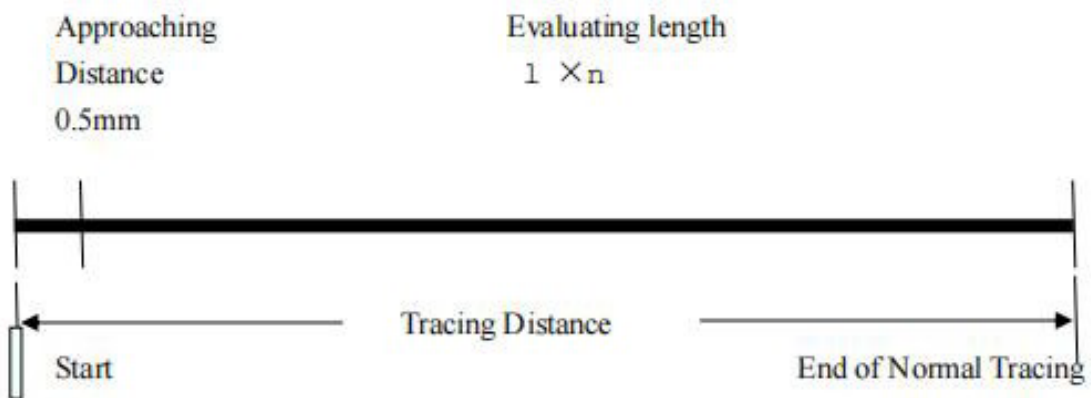

6.2 Parameters Definitions

6.2.1 Arithmetical Mean Deviation of Profile Ra

Ra is arithmetic mean of the absolute values of profile deviation $Z(x)$ from mean within sampling length.

$$Ra = \frac{1}{l} \int_0^l |Z(x)| dx$$

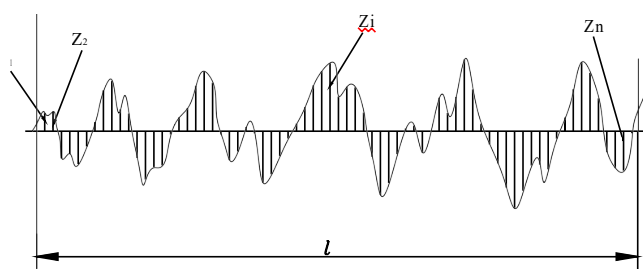

6.References

6.2.2 Root-mean-square Deviation of Profile R_q

R_q is the square root of the arithmetic mean of the squares of profile deviation $Z(x)$ from mean within sampling length.

$$R_q = \sqrt{\frac{1}{l} \int_0^l Z^2(x) dx}$$

6.2.3 Maximum Height of Profile R_z

R_z is The sum of height Z_p of the highest profile peak from the mean line and depth Z_v of the deepest profile valley from the mean line within sampling length.

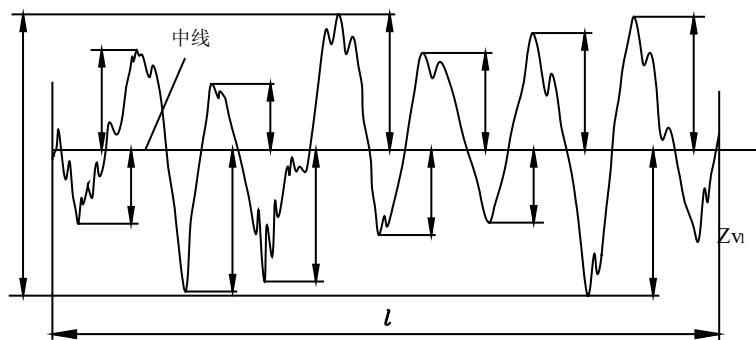

6.2.4 Total Peak-to-valley Height R_t

R_t is the sum of the height of the highest peak Z_p and the depth of the deepest valley Z_v over the evaluation length.

6.2.5 Maximum height of Profile Peak R_p

R_p is the height from the highest profile peak line to mean line within sampling length

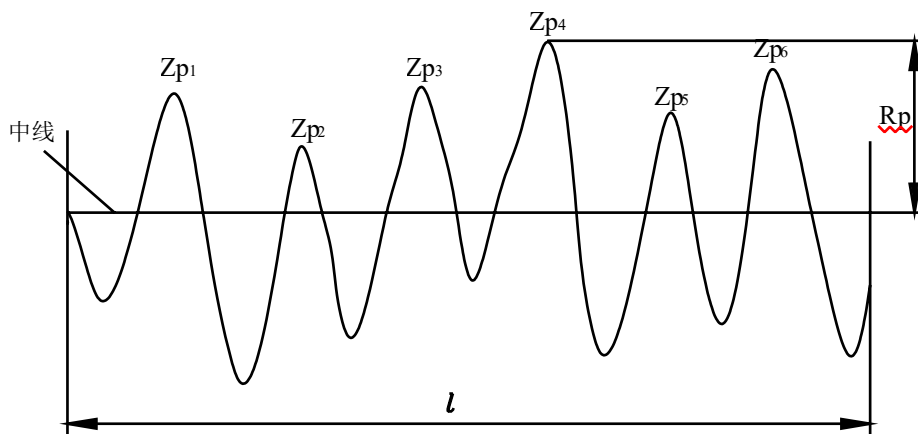

6. References

6.2.6 Maximum Depth of Profile Valley R_v

R_v is the depth from the deepest profile valley line to mean line within sampling length.

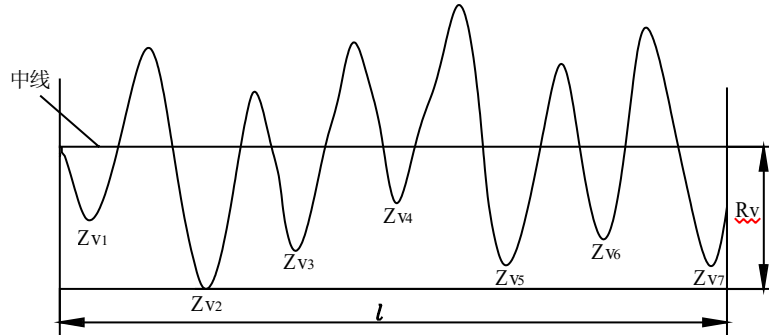

6.2.7 Mean Spacing of Local Peaks of Profile RS

RS is the mean spacing of adjacent local peaks of the profile within sampling length.

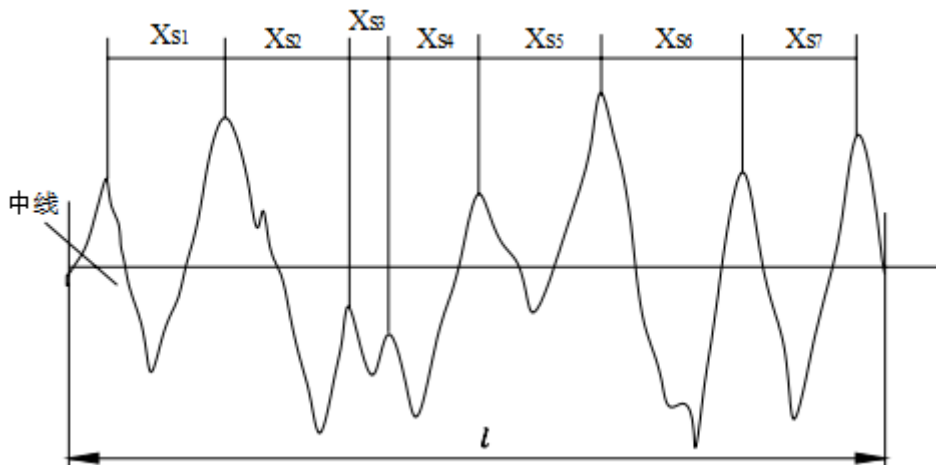

6.2.8 Mean Spacing of Profile elements RS_m

RS_m is the mean spacing between profile peaks at the mean line within sampling length.

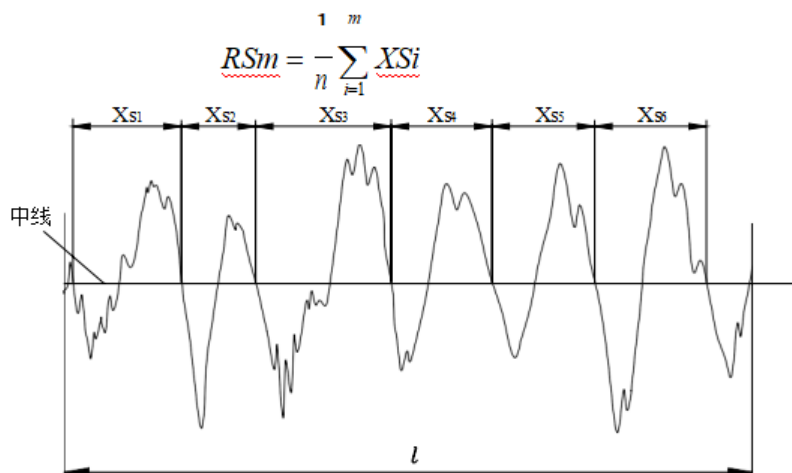

6. References

6.2.9 Ten Point Height of Irregularities RzJIS

The sum of the mean height of the five highest profile peaks and the mean depth of the five deepest profile valley from mean within the sampling length.

$$Rz_{JIS} = \frac{1}{5} \sum_{i=1}^5 \overline{Y_{p_i}} + \frac{1}{5} \sum_{i=1}^5 \overline{Y_{v_i}}$$

6.2.10 Maximum Height of Profile RyJIS

The same to 6.2.3 Rz.

6.2.11 Skewness of the profile RSk

RSk is the quotient of the mean cube value of the profile deviation (Y_i) and the cube of Rq within sampling length.

$$Rsk = \frac{1}{Rq^3} \left[\frac{1}{lr} \int_0^{lr} Z^3(x) dx \right]$$

6.2.12 Third Maximum Peak-to-valley Height R3z

R3z is the mean of the sum of the third profile peak height and the third profile valley depth of each sampling length over evaluation length.

$$R3z = \sum_{i=1}^{i=n} R3z_i$$

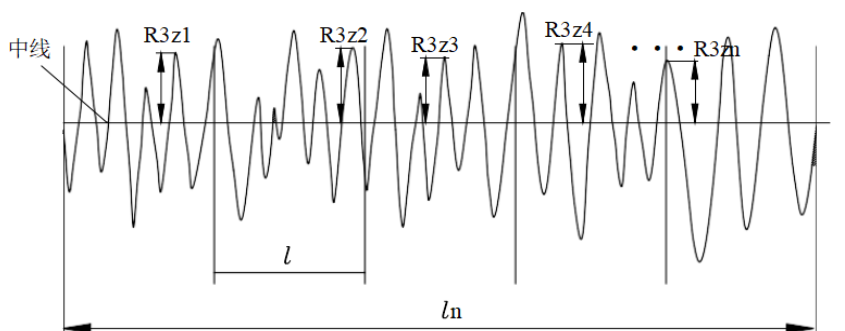

6. References

6.2.13 R_{max}

The same to 6.2.4 R_t.

6.2.14 Peak count R_{pc}

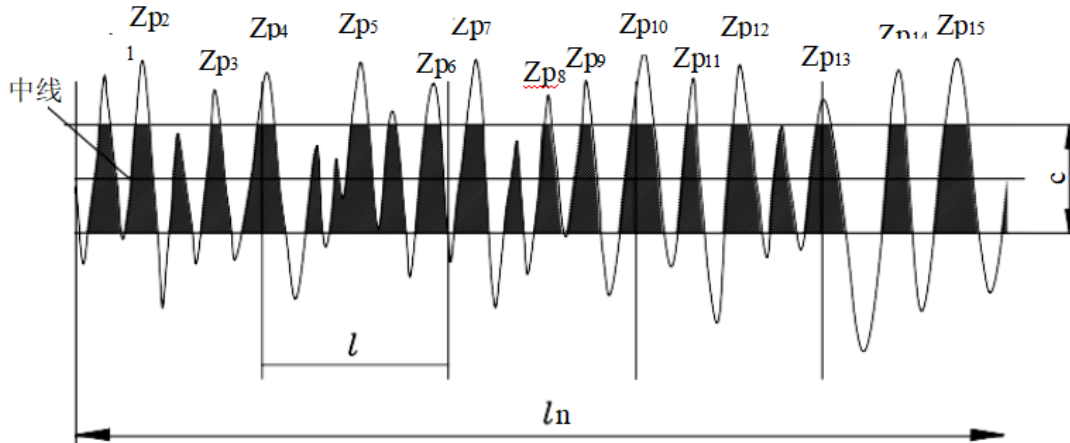

6.2.15 Material ratio curve of profile R_{mr}

The material ratio of change with horizontal position and the relationship between the curve.

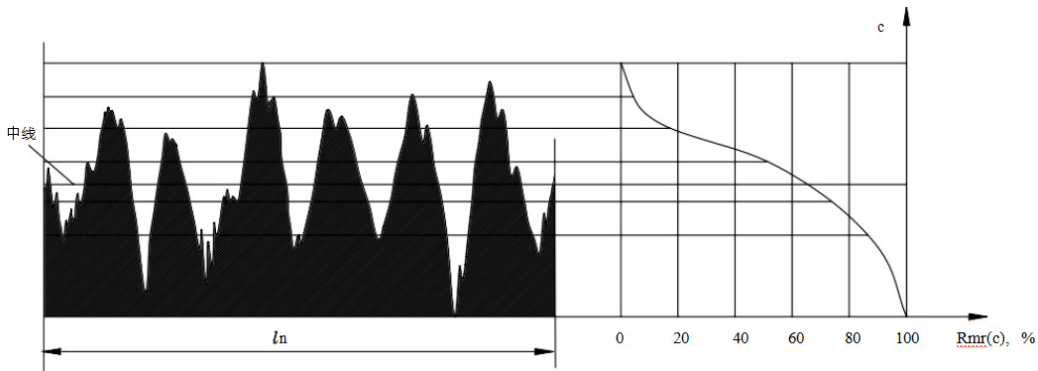

6.2.16 Material length ratio R_{mr}(c)

Horizontal position in a given contour C on the physical materials and the assessment length of the length ratio.

$$R_{mr}(c) = \frac{\text{Material length (c)}}{\text{Evaluation length}}$$

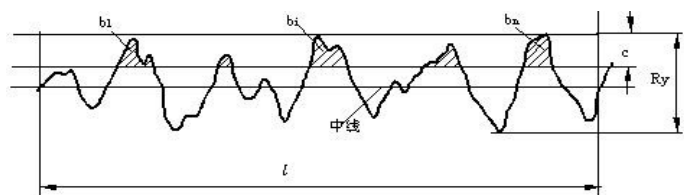

6.References

6.3 Recommended table of the sampling length

Ra (μm)	Rz (μm)	Sample length $\lambda_c(\text{mm})$
> 5 ~ 10	> 20 ~ 40	2.5
> 2.5 ~ 5	> 10 ~ 20	
> 1.25 ~ 2.5	> 6.3 ~ 10	0.8
> 0.63 ~ 1.25	> 3.2 ~ 6.3	
> 0.32 ~ 0.63	> 1.6 ~ 3.2	
> 0.25 ~ 0.32	> 1.25 ~ 1.6	0.25
> 0.20 ~ 0.25 > 0.16 ~ 0.20	> 1.0 ~ 1.25 > 0.8 ~ 1.0	
> 0.125 ~ 0.16 > 0.1 ~ 0.125 > 0.08 ~ 0.1	> 0.63 ~ 0.8 > 0.5 ~ 0.63 > 0.4 ~ 0.5	
> 0.063 ~ 0.08 > 0.05 ~ 0.063 > 0.04 ~ 0.05	> 0.32 ~ 0.4 > 0.25 ~ 0.32 > 0.2 ~ 0.25	
> 0.032 ~ 0.04 > 0.025 ~ 0.032 > 0.02 ~ 0.025	> 0.16 ~ 0.2 > 0.125 ~ 0.16 > 0.1 ~ 0.125	

7.Packing List

Number	Name	Quantity	Remarks
1	Main Unit	1	
2	Sensor	1	Precision parts
3	Calibration Block	1	
4	Block Bracket	1	
5	Charger	1	
6	USB Charging cable	1	
7	Operating manual	1	
8	Certificate	1	
9	Guarantee Card	1	
10	Instrument Container	1	
11	Software	1	

Mikrosize Distributors Worldwide

Coventry,UK /Warsaw,Poland/Burago di Molgora, Italy/Langgöns,Germany/
Madrid, Spain/Istanbul,Turkey/Minsk,Belarus/Moscow , Russia /Sao Paulo, Brazil/
Mexico City ,Mexico/Penang, Malaysia/Bangkok Thailand etc.....



Anhui Mikrosize Precision Instrument Co.,Ltd

Factory Producing Add: N013 Shuiku Road Shatou, Changan Town, Dongguan, China.

International Trading Office: A-4035 RuiFeng Business Expo , Wuhu City, China.

Web: www.mikrosize.com Email: mikrosize@mikrosize.com

