



# iThick-200 Ultrasonic Thickness Gauge

## Instruction Manual



**Anhui Mikrosize Precision Instrument Co.,Ltd**

**Add:** A-4035 RuiFeng Business Expo, Wuhu City, China, 241000.

**Web:** [www.mikrosize.com](http://www.mikrosize.com) **Email:** [mikrosize@mikrosize.com](mailto:mikrosize@mikrosize.com)

# Contents

<b>1. Brief Introduction.....</b>	<b>1</b>
<b>2. Testing and Operation.....</b>	<b>4</b>
<b>3. Measruing Technique .....</b>	<b>18</b>
<b>4. Prevention of Measurement Error .....</b>	<b>22</b>
<b>5. Matters Needing Attention.....</b>	<b>24</b>
<b>6. Repair and Maintenance .....</b>	<b>25</b>
<b>7. Packing List .....</b>	<b>26</b>
<b>8. Appendix .....</b>	<b>27</b>

# 1. Brief Introduction

## 1.1 Application Field

The thickness gauge adopts the Interface-Echo-Echo ultrasonic measurement principle (IE), which is suitable for the measurement of the thickness of various materials in which the ultrasonic can propagate at a constant speed and get the reflection from the back. At the same time, it is also equipped with a test function to check whether the precious metals are adulterated and identify the purity. It is mainly used for the identification of gold bars, silver bars, gold coins, silver coins and other precious metals. This instrument can accurately measure all kinds of plates and processed parts. It is widely used in petroleum, chemical industry, metallurgy, shipbuilding, aviation, aerospace and other fields.

## 1.2 Working Theory

The principle of ultrasonic thickness measurement is similar to that of light wave measurement. The ultrasonic pulse emitted by the probe reaches the measured object and propagates in the object. When it reaches the material interface, it is reflected back to the probe. The thickness of the measured material is determined by accurately measuring the time of ultrasonic propagation in the material.

## 1.3 Name of Each Part of the Instrument



# 1. Brief Introduction

## 1.4 Instrument Features

- Three measurement modes, P-E I-E and test, are adopted to accurately measure the thickness; I-E mode enables the gage to measure thickness through coating;
- high precision timing chip and v-path calibration model are adopted, with wide measurement range and high measurement accuracy;
- the measurement information can be completely stored, including thickness measurement value, measured sound velocity and time information;
- two No. 5 alkaline batteries are used for power supply;
- the display resolution is 0.01mm, and the error limit is 0.4% H (H is the thickness of the working piece);
- the contrast of liquid crystal display is adjustable, and has LED backlight display, which can be used in various light environments.

## 1.5 Main Functional Parameters

- it has zero calibration, which can automatically correct the system error;
- if the thickness is known, the sound velocity can be measured back to improve the measurement accuracy;
- it has the coupling state prompt function to intuitively grasp the measurement state;
- it has the power indication function, which can display the remaining power of the battery in real time.

# 1. Brief Introduction

## 1.6 Technical Parameters

	Basic Type	Cast Iron Type	High Precision Type	High Temperature Type
Testing Range(Steel)	1.0~250mm	2.0~400mm	0.75~35mm	4.0~80mm
Display Error(<10 mm)	±0.04mm	±0.04mm	±0.04mm	±0.05mm
Testing Error(≥10 mm)	±0.4%H mm	±0.4%H mm	±0.4%H mm	±0.4%H mm
Testing Frequency	5MHz	2MHz	7.5MHz	3MHz
Display Accuracy	0.01mm			
Measurement period	4 times/second			
Velocity Range	1000-9999m/s			
Display	FSTN LCD display, with cold light source illumination display			
Working Voltage	2*1.5V			
Continuous Working time	50 hours (without backlight)			
Data Storage	500 groups of measurement results, including measurement time and sound velocity information			
Auto Power off	Automatic shutdown without action for 2 minutes (settable), with switch button			
Display Content	Thickness value, coupling state, electric quantity state, calibration state, sound velocity, time, etc			
Size	155mm X 68mmX27mm			
Weight	230g			

## 2. Testing and Operation

### 2.1 Measuring Preparation

2.1.1 Insert the probe plug into the host probe socket.

Press the key to start the instrument, and the screen display is shown in the following figure:

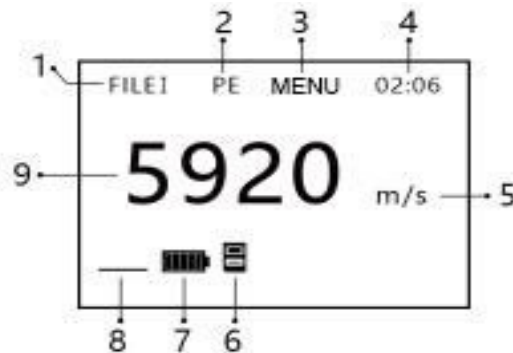

1. Current document number (five documents in total)
2. Measurement mode (test / PE mode is optional)
3. Menu options (select menu to set instrument parameters and realize relevant functions)
4. System time
5. Sound velocity unit (thickness unit displayed during measurement)
6. Automatic storage flag
7. Battery power indication (when the power indication is , it is recommended to replace the battery)
8. Coupling signal sign
9. Display value (display measured value during measurement)

#### 2.1.2 Measurement mode selection

Press the **MODE** key to move the cursor to ie, press the **←** key to switch among "IE", "test" and "PE", and select the required measurement mode. Press **MODE** or **VEL** to confirm and exit. As shown below.



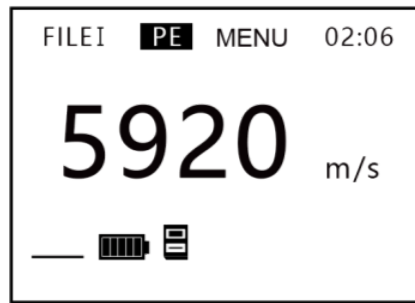

## 2. Testing and Operation



"PE" is the principle of pulse reflection ultrasonic measurement, which is applicable to the measurement of the thickness of various materials in which the ultrasonic can propagate at a constant speed and get the reflection from the back.

"Test" is to use ultrasonic technology to check whether precious metals are adulterated and identify their purity. It is mainly used for the identification of gold bars, silver bars, gold coins and silver coins.

### 2.1.3 Set probe frequency

Press the  key to move the cursor to the menu (as shown in the figure below), and press the  key to enter the menu. Select "system setting" by pressing the  key, and then press  to enter the system interface. Select "probe" by pressing the  key, and then press to select the probe model.



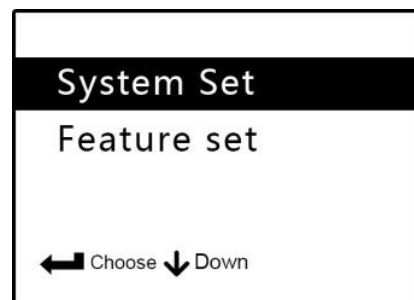

Each press  will display 5m, 7m, 2M and h2m in turn. After selection, press to confirm and exit.



Note: the probe frequency setting must be consistent with the probe frequency used, otherwise the measurement accuracy will be affected.

## 2. Testing and Operation

### 2.2 Velocity Adjustment

If the current screen displays the thickness value, press the  key to enter the Velocity (sound speed) display, and the screen will display the current velocity. Then press the  key to cycle and select five common sound speeds. Each time you press the  key, you can select one common velocity, including fixed steel (5920m / s), gold (3240m / s), silver (3650m / s), platinum (3960m / s), palladium (3070m / s) and a user-defined velocity. When the user-defined sound speed is selected, the velocity value can be adjusted by pressing the key. After confirmation, press  and exit. As shown in the figure below:

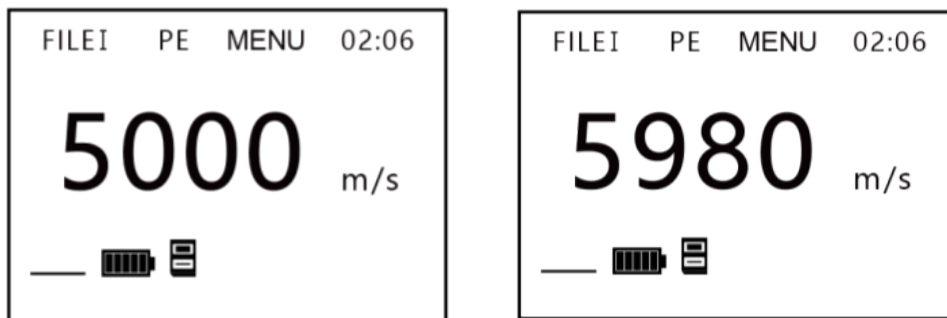

Due to the high measurement accuracy, the small change of sound velocity directly affects the measurement results, especially for the thicker measured object, so the accurate measurement requires the input of accurate sound velocity value. If the sound velocity of the measured object is uncertain, the method in the chapter "sound velocity calibration" can also be used to take a known thickness test block of the same material to measure the sound velocity. In addition, the sound velocity will change with the change of temperature. In the measurement, pay attention to updating the sound velocity value with the change of temperature.

### 2.3 Zero Calibration

After replacing the probe, changing the measurement mode or changing the ambient temperature, it is necessary to calibrate the zero point of the instrument before

## 2. Testing and Operation

measurement. The steps are as follows:

- a. Adjust the sound speed to 5920m / s, which is the sound speed of steel, that is, the sound speed of the standard test block attached to the thickness gauge;
- b. Then apply the couplant (coupling agent) to the random test block, couple the probe with the random test block to measure, press the  key to start zero calibration after the coupling is good on the screen, and the calibration progress bar is displayed on the screen;
- c. After the calibration progress bar is displayed, "4.00mm" is displayed on the screen, indicating that the calibration is successful; The display of "X" on the screen indicates that the calibration fails, indicating that the coupling is not good during the calibration process and needs to be calibrated again.

Note: if the value displayed on the screen is not 4.00 after successful calibration, please check whether the currently set sound speed is 5920.



### 2.4 Thickness Measurement

First set the sound velocity, then apply the couplant to the measured position, and then couple the probe with the measured material to measure (the fuller the coupling mark grid, the better the coupling effect). The screen will display the thickness of the measured material. After removing the probe, the thickness value will remain and the coupling mark will disappear. As shown in the figure below:

## 2. Testing and Operation



When the probe is coupled with the tested material, the coupling mark is displayed. If there are less than 5 grids in the coupling flag, the coupling is not good.

Note: 1. When the probe leaves the tested part, the "coupling change value" may be measured, and an error value stays on the display screen. Therefore, to record the measured value, it is best to freeze the value by shortly pressing key before the probe is lifted.

2. If there is a large deviation between the measured value and the real value during coupling, it indicates that the instrument has made a wrong judgment on the measured object. Please lift the probe and measure again until the correct value appears.

### 2.5 Sound Velocity Calibration

If you want to measure the sound velocity of a material, you can use a test block with known thickness to measure the sound velocity. First measure the test block with vernier caliper or micrometer and accurately read the thickness value. First select the sound speed as the user-defined sound speed, and then couple the probe with the test block of known thickness until the stable thickness value is displayed. Press the SAVE key to freeze the thickness display value (the freezing mark "\*" is displayed on the screen). After removing the probe, press the ▲ or ▼ key to adjust the display value to the actual thickness value, and then press the VEL key to reverse calculate the sound speed. The reverse calculation progress bar appears on the screen, The measured sound speed will be displayed after the

## 2. Testing and Operation

reverse calculation of sound speed is successful, and the sound speed will be stored in the current sound speed storage unit. The test block with sufficient thickness must be selected for sound speed measurement. The minimum wall thickness is recommended to be 4.0mm for sound speed calibration. If "X" is displayed after the reverse calculation of sound speed progress bar, it indicates that the reverse calculation of sound speed fails and the current sound speed will not be changed. The reasons for the failure of inverse calculation of sound velocity may be: 1) it is not frozen during coupling; 2) Inverse calculation of sound speed overrun: 3) no custom sound speed is selected.

### 2.6 Language Setting

The thickness gauge has Chinese, English and Spanish display functions. The function setting steps are as follows:

- a. Press the key to move the cursor to "menu", as above.
- b. Press to enter the menu interface.
- c. Press to select the menu item "system setting" and press to enter.
- d. The key cycle displays Chinese, English and Spanish, as shown in the following figure:

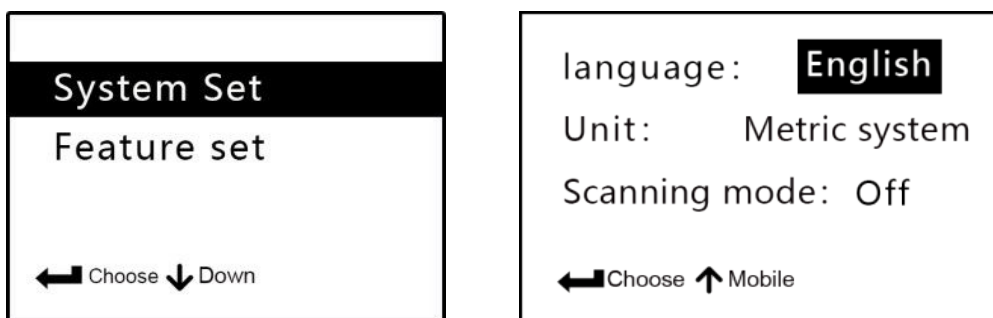

- e. After selection, press the key to confirm the setting and return to the main interface.

### 2.7 Setting Measurement Units

The thickness gauge has two measurement units, metric and English, and its setting steps refer to Section 2.6.

## 2. Testing and Operation

### 2.8 Setting the Scanning Mode

The thickness gauge has scanning mode and can be switched on and off. Refer to Section 2.6 for its setting steps.

If the scanning mode is on, as shown in the figure below, "SCN" will be displayed at the bottom of the screen. There is no SCN indication on the screen, indicating that the instrument is in single point measurement mode.

In the scanning mode, the thickness measurement is in the real-time display mode. When the coupling state is good, the movable probe can carry out continuous measurement.



### 2.9 Setting Buzzer

Refer to Section 2.6 for setting steps.

When the buzzer mode is turned on, a prompt tone will be given when operating the instrument. When the buzzer mode is turned off, the instrument is in a quiet operation state.

### 2.10 Set flashing Alarm

Refer to Section 2.6 for setting steps.

The function of flashing alarm is mainly used to enable in the test mode. When the test passes, the screen model displays "pass" or "cal" and the key will flash yellow. When the test fails, the screen model displays "fail" and the key will flash red.

## 2. Testing and Operation

### 2.11 Setting the Probe



Refer to Section 2.6 for setting steps.



Before the test, the parameters of the probe shall be set to be consistent with the measured probe parameters before more accurate values can be measured. (refer to Section 2.1 for details)

### 2.12 Setting Recovery Recognition Settings

a. Press  to move the cursor to menu.

b. Press  to enter the menu interface.



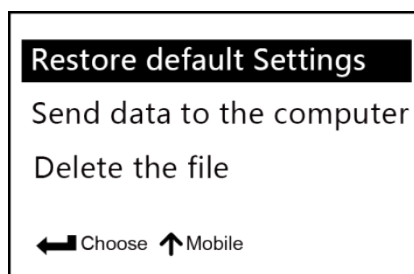

c. Press  or  to select the "function setting" option, and press  to enter the function setting interface.

Press the  or  key to select the "restore recognition setting" option, and press  the key to complete the setting. After setting, press OK and exit. As shown in the figure below



### 2.13 Setting Sending Data to Computer

Refer to section 2.12 a, b and C for setting steps.



Press the  or  key to select the "send data to computer" option, and press the  key to complete the setting. After setting, press  and exit.

This function is optional and can be equipped after contacting the manufacturer.

### 2.14 Setting and Deleting Files

Refer to section 2.12 a, b and c for setting steps.

## 2. Testing and Operation

Press  or  to select the "delete file" option and press  to complete the deletion function.

This function is to delete the contents of the currently selected folder. After setting, press  and exit.

### 2.15 Setting and Deleting All Data



Refer to section 2.12 a, B and C for setting steps.



Press  or  to select the "delete all data" option, and press  to finish deleting all data.

This function is to delete the data saved in all folders.

### 2.16 Setting Contrast



Refer to section 2.12 a, B and C for setting steps.



Press  or  to select the "set contrast" option, and press  to enter the adjustment interface.

There are 10 levels of contrast settings displayed on this function screen. Users can press  or  key to set the contrast according to their preferences. After setting, press  and exit.

### 2.17 Setting System Time

Refer to section 2.12 a, B and C for setting steps.

Then press  or  to select the "set system time" option, and press  to enter the adjustment interface.

This function is to adjust the instrument system and display time. After entering the interface, press  to select the content to be adjusted, and press  or  to adjust the value. The display is year month day hour minute in turn.





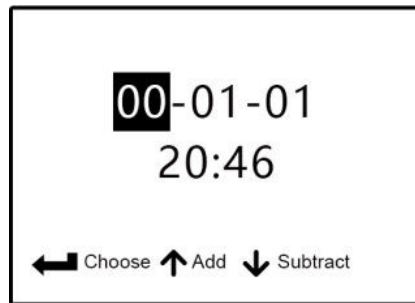

The display is shown in the figure below. After setting, press  and exit.

## 2. Testing and Operation



### 2.18 Setting Standby Time



Refer to section 2.12 a, b and c for setting steps.

Then press  or  to select the "set standby time" option, and press  to enter the adjustment interface. Press the  or  key to adjust the standby time. The default standby time of the instrument is 2 minutes, and the maximum standby time can be set to 20 minutes. After setting, press  and exit.

Note: if the standby time is 00 minutes, the instrument will not shut down automatically.

### 2.19 Version Information Viewing

Refer to section 2.12 a, B and C for setting steps.

Then press  or  to select the "version information" option, and press  to enter the interface. The display is shown in the figure below.

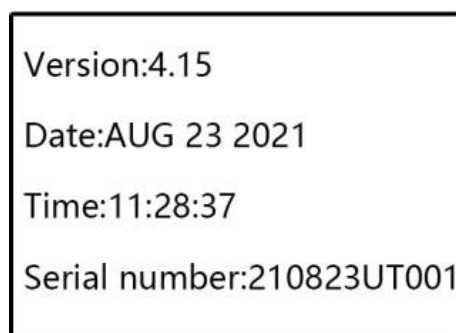

### 2.20 Thickness Value Storage, Viewing and Deletion

The thickness gauge has the function of measuring data storage. The instrument divides the storage unit into 5 files, and each file can store 100 groups of measuring data. Each group of measurement data contains complete measurement information, including

## 2. Testing and Operation



thickness value and measurement time. The file number shall be set before storing data.

The specific operation steps are as follows.

### 2.20.1. Set storage file

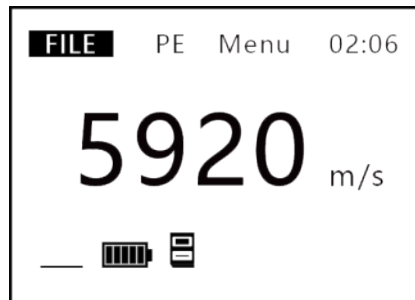

a. Press the  key to move the cursor to "file I", as shown in the following figure:





Press the key, the file number is displayed circularly according to file I ~file V, and press the  key or  key to return to the measurement mode. Note: each file can only store 100 groups of data. When it is full, a prompt will be given (the file is full!), You can set other files for storage according to the above steps.

### 2.20.2 Save the measurement results manually

A. During or after the measurement, press the  key shortly, and the "\*" sign is displayed on the screen, indicating that the current measurement result has been frozen;

B. When the measurement results are frozen, press the  key long to save and unfreeze the currently frozen measurement results, and press the key shortly  key to unfreeze directly without saving.



### 2.20.3 Automatically Save Measurement Results

A. When the measurement results are not frozen, press the  key for a long time, the "" automatic storage flag  is displayed at the bottom of the screen, and the instrument enters the automatic storage mode;

B. When each measurement is completed, accompanied by two rings, the measurement results are automatically saved to the current file.

## 2. Testing and Operation

### 2.20.4 View Stored Content

A. Press the  key to move the cursor to "file I", and press the key  to switch and select the file;

B. Press the  key to view the status of the stored content, as shown in the following figure:





Note: 001 is the serial number of the currently displayed stored data, 007 is the total quantity of the stored data in the current file, 00-01-01 is the measurement date, 21:48 is the measurement time, and 4.00mm is the measurement thickness value. 5920 is the speed of sound used for the measurement.

C. Press the  or  key to view all stored data;

D. Press  to delete the current data and display the next stored value.

E. Press  to return

### 2.21 Backlight





The thickness gauge has the function of backlight. In the power on state, press  once to turn on the backlight. In the backlight on state, press  again to turn off the backlight.

### 2.22 Test Function





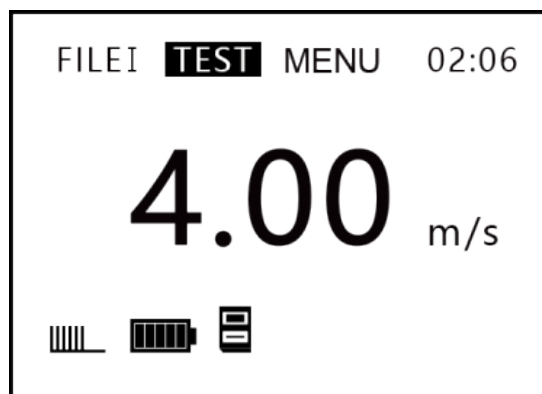

The thickness gauge develops a test function for testing gold or other precious metals. It uses ultrasonic technology to check whether the precious metals are adulterated and identify the purity. It is mainly used for the identification of gold bars, silver bars, gold

## 2. Testing and Operation

coins and silver coins. At the same time, it can also quickly detect whether the thickness of the product is qualified.

A. Press the key  to move the cursor to the "test" or "PE" position, press  the key to switch and select the "test" mode, and then press  the key until the cursor disappears, exit and select to enter the measurement mode, or press  to enter the measurement mode directly. See the figure below.



a. Press the  key to select the material to be tested, including steel, gold, silver, platinum, palladium, and users (press the  or  key to set the sound velocity value by themselves). Then press  to set the thickness of the measured material, and press  or  to adjust the value. Press  save again and exit.

b. Then measure. If the measured material meets the setting requirements, the screen will display as follows, and the  key will display a green light.

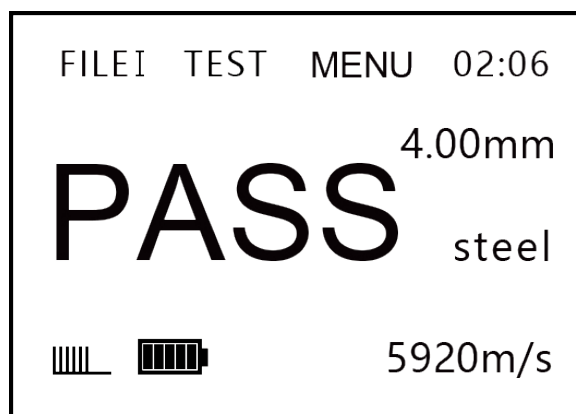

## 2. Testing and Operation

If the tested material does not meet the setting requirements, the screen will display as follows, and the  key will display red light.

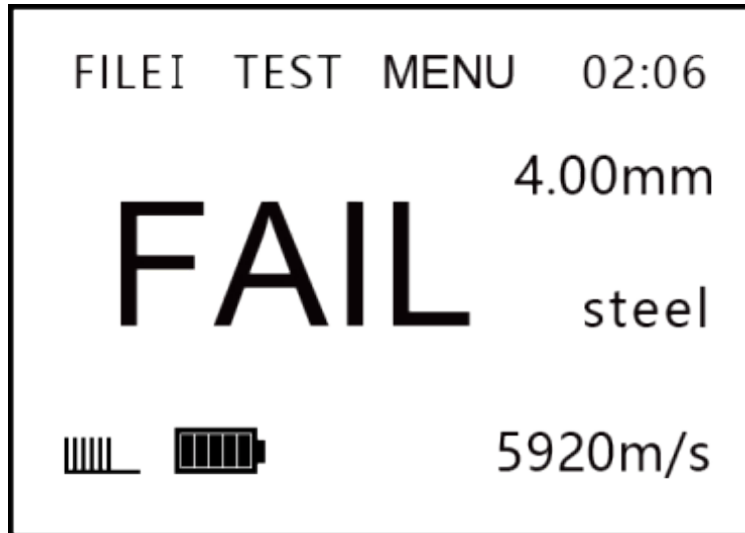

### 2.23 Shutdown Mode

The thickness gauge has two shutdown modes: automatic shutdown and manual shutdown. It will shut down automatically without any operation for about two minutes. It can be shut down at any time with a long pressing  key.

## 3.Measurement Technology

### 3.1Cleaning Surfaces

Before measurement, all dust, dirt and rust on the surface of the measured object shall be removed, and paint and other covers shall be removed.

### 3.2Improve Roughness Requirements

Excessively rough surface will cause measurement error and even no reading of the instrument. Before measurement, try to make the surface of the measured material smooth, which can be made smooth by grinding, polishing, filing and other methods. High viscosity couplants can also be used.

### 3.3Measuring Cylindrical Surfaces

When measuring cylindrical materials, such as pipes, oil drums, etc., the most ideal situation is when the probe axis intersects with the axis of the measured material. Simply put, couple the probe with the measured material, then rotate the probe around the axis of the measured object or move the probe parallel to the axis of the measured object to make the center line of the probe delay block contact with the measured object, and select a stable reading as the accurate thickness of the material. It will be helpful to choose different delay blocks for the measured objects with different diameters. A piece of fine sandpaper can be covered on the surface of the measured object, and then move the probe back and forth, which will easily grind the arc at the front end of the probe delay block.

### 3.4Non Parallel Surfaces

In order to obtain a satisfactory ultrasonic response, the other surface of the measured material must be parallel or coaxial with the measured surface, otherwise it will cause measurement error or no reading display at all.

## 3.Measurement Technology

### 3.5Temperature Effect of Materials

The thickness of material and ultrasonic propagation speed are affected by temperature. If the measurement accuracy is high, the test block comparison method can be used, that is, use the test block of the same material to measure under the same temperature conditions, obtain the temperature compensation coefficient, and use this coefficient to correct the measured value of the measured working piece.

### 3.6Large Attenuation Materials

For some materials such as fiber, porous and coarse particles, they will cause a large amount of scattering and energy attenuation of ultrasonic wave, resulting in abnormal readings or even no readings (usually the abnormal readings are less than the actual thickness). In this case, it indicates that the material is not suitable for testing with this thickness gauge.

### 3.7Reference Test Block

For accurate measurement of different materials under different conditions, the closer the material of the calibration block is to the measured material, the more accurate the measurement is. The ideal reference test block will be a group of test blocks with different thicknesses of the tested materials. The test block can provide instrument compensation correction factors (such as material micro structure, heat treatment conditions, particle direction, surface roughness, etc.). In order to meet the requirements of maximum accuracy measurement, a set of reference test blocks will be very important. In most cases, satisfactory measurement accuracy can be obtained by using only one reference block with the same material and similar thickness as the measured material. Take the uniform measured material and use it as a test block after measuring with a micrometer.

## 3.Measurement Technology

For thin materials, when its thickness is close to the lower limit of probe measurement, the test block can be used to determine the accurate lower limit. Do not measure material below the lower limit thickness. If a thickness range can be estimated, the upper limit of the thickness of the test block shall be selected. When the measured material is thick, especially the alloy with complex internal structure, select one close to the measured material in a group of test blocks to facilitate calibration. The internal structure of most forgings and castings is directional, and the sound velocity will change a little in different directions. In order to solve this problem, the test block should have the internal structure in the same direction as the tested material, and the propagation direction of sound wave in the test block should also be the same as that in the tested material.

In some cases, the reference test block can be replaced by checking the sound velocity of known materials, but this only approximately replaces some reference test blocks. In some cases, the value in the velocity is different from the actual measurement because of the differences in the physical and chemical conditions of the materials. This method is often used to measure low carbon steel, but it can only be used as a rough measurement. The thickness gauge has the function of back measuring sound velocity, so the sound velocity can be measured first, and then the working piece can be measured with this sound velocity.

### 3.8Several Methods in Measurement

A.Single measurement: measurement at one point.

B.Double measurement method: the probe shall be used for two measurements at one point, and the probe positions shall be perpendicular to each other in the two measurements. Select the minimum of the readings as the exact thickness of the material.

C.Multi-point measurement method: multiple measurements are carried out within a certain measurement range, and the minimum value is the material thickness value.

## 3.Measurement Technology

### 3.9Probe Selection

Model	Features Descripton	Frequency (MHz)	Diameter of Contact Area (mm)	Measuring Range(steel) (mm)	Allowable contact temperature (°C)
5Mhz probe	Universal use	5	10	1.0~250.0	-10~60
2M Coarse crystal probe	Special use	2	12	2.0~400.0	-10~60
7M Micro diameter probe	Special use	7.5	6	0.75~35.0	-10~60
H2MHigh Temperature probe	Special use	3	12	4.0~80.0	-10~310

## 4.Prevention Method of Measurement Error

### 4.1Ultra Thin Materials

Using any ultrasonic thickness gauge, when the thickness of the measured material falls below the lower limit of the probe, it will lead to measurement error. If necessary, the minimum limit thickness can be measured by the test block comparison method.

When measuring ultra-thin materials, sometimes an error result called "double refraction" occurs. Its result is that the display reading is twice the actual thickness. Another error result is called "pulse envelope and cycle jump". Its result is that the measured value is greater than the actual thickness. In order to prevent this kind of error, repeat the measurement and check when measuring critical thin materials.

### 4.2Rust Spots, Corrosion Pits, etc

Rust spots and pits on the other surface of the tested material will cause irregular changes in readings, even no readings in extreme cases, and small rust spots are sometimes difficult to find. When a pit is found or suspected, the measurement of this area must be very careful. The positioning of the probe at different angles can be selected for multiple tests.

### 4.3Material Identification Error

When the instrument is calibrated with one material and another material is tested, wrong results will occur. Pay attention to selecting the correct sound velocity.

### 4.4Probe wear

The surface of the probe is made of propylene resin. Long term use will increase the roughness and reduce the sensitivity. When the user can determine that the error is caused by this reason, the user can polish the surface of the probe with a small amount of sandpaper or oilstone to make it smooth and ensure parallelism. If it is still unstable,

## 4.Prevention Method of Measurement Error

replace the probe.

### 4.5Influence of oxide layer on metal surface

Some metals can produce a dense oxide layer on their surface, such as aluminum. This oxide layer is closely combined with the matrix without obvious interface, but the propagation speed of ultrasonic wave in these two substances is different, so it will cause errors, and the errors are different with different oxide layer thickness. Please pay attention to it when using, You can select a sample block from the same batch of measured materials and measure it with a micrometer or caliper to calibrate the instrument.

### 4.6Abnormal thickness readings

The operator shall have the ability to distinguish abnormal readings.

Generally, rust spots, corrosion pits and internal defects of the tested material will cause abnormal readings. Refer to chapters 4 and 5 for solutions.

### 4.7Use and selection of coupling agent

The couplant is used as a high-frequency ultrasonic energy transfer between the probe and the measured material. If the type or use method is improper, it may cause error or the coupling mark flashes, and the value cannot be measured. Couplant shall be used in proper amount and coated evenly. It is important to select a suitable kind of coupling agent. When used on smooth material surface, low viscosity coupling agent (such as randomly configured coupling agent, light machine oil, etc.) is very suitable. When used on rough material surfaces, or vertical surfaces and top surfaces, coupling agents with high viscosity (such as glycerin paste, butter, grease, etc.) can be used. Couplant of various formulations are available everywhere.

## 5. Matters Needing Attention

### 5.1 Cleaning of Test Block

Since the coupling agent needs to be coated when the random test block is used to test the instrument, please pay attention to rust prevention. Clean the random test block after use. Don't sweat when the temperature is high. If it is not used for a long time, the surface of the random test block shall be coated with a little grease for rust prevention. When it is used again, it can work normally after wiping the grease.

### 5.2 Cleaning of Casing

Alcohol and diluent can corrode the casing, especially the window, so when cleaning, gently wipe it with a small amount of water.

### 5.3 Probe Protection

The probe surface is very sensitive to the redrawing of rough surface, so it should be gently pressed in use. When measuring the rough surface, try to reduce the scratch of the probe on the working surface. During normal temperature measurement, the surface of the measured object shall not exceed 60 °C, otherwise the probe cannot be used again. The adhesion of oil and dust will gradually aging and fracture the probe wire. After use, remove the dirt on the cable.

### 5.4 Battery Change

When the power of the instrument is too low, replace the battery in time as follows:

Press the  button to shut down, open the battery compartment cover and take out the battery.

Put the charged No. 7 alkaline battery into the battery compartment (pay attention to the battery polarity) and cover the battery compartment cover.

When the instrument is not used for a long time, the battery shall be taken out to avoid battery leakage and corrosion of the instrument.

## 6.Repair and Maintenance

### 6.1Testing Problem

If the measurement error is too large, please refer to Chapter 4 and 5. If the following problems occur, please contact the maintenance department of our company:

- a.The instrument is damaged and cannot be measured.
- b.The LCD display is abnormal.
- c.In normal use, the error is too large.
- d.Keyboard operation failure or confusion.

As the thickness gauge is a high-tech product, the maintenance work should be completed by professionally trained maintenance personnel. Please do not disassemble and repair it by yourself.

The following accessories and accessories are not included in the warranty: Probe, test block, couplant , battery, casing, window and key film.

## 7.Packing List

	Name	Quantity
Standard Configurations	Host	1
	Probe	1
	Couplant	1
	Manual	1
	Guarantee Card	1
	Qualification Certificate	1
	Packaging Box	1
Optional Configurations	High temperature Probe	1
	Cast Iron Probe	1
	Precision Probe	1
	High Temperature Coupling	1

## 8. Appendix

### Appendix: sound velocity of various materials

Media Material Name	Velocity (m/s)
Aluminium	6320
Chromium	6200
Copper	4700
Gold	3240
Iron	5930
Lead	2400
Magnesium	5750
Silver	3600
Steel	5900
Titanium	5990
Zinc	4170
Tungsten	5174
Tin	3320
Brass	4280—4700
Cast Iron	4400—5820
Glass	5260—6120
Nylon	2680
Stainless Steel	5740
Water (20 °C)	1480
Glycerol	1920
Water Glass	2350

Note: the sound velocity in the above table is for reference only, and the actual sound velocity calibration refers to Section 3.1

### User Notice

1. After purchasing the company's products, please carefully fill in the warranty registration card and affix the user's official seal. Please send the copy of warranty registration card and purchase invoice back to the user service department of the company, or entrust the seller to send it on behalf when purchasing the machine. If the procedures are incomplete, it can only be repaired without warranty.

2. If the company's products have quality faults within one year from the date of purchase (except for non warranty parts), please contact the maintenance stations of branches around the company with the "warranty card" or the copy of purchase invoice to repair,

## 8. Appendix

replace or return the products. During the warranty period, the warranty card or copy of purchase invoice cannot be presented. The company calculates the warranty period according to the factory date for one year.

3.If the company's products beyond the warranty period fail, local maintenance stations are responsible for after-sales service and product maintenance, and charge maintenance fees according to the company's regulations.

4.The "special configuration" (special probe, special software, etc.) outside the finalized products of the company shall be charged according to relevant standards.

5.The company cannot provide warranty for any product damage caused by the user's disassembly and assembly of the company's products, improper transportation, storage or incorrect operation according to the "product operation manual", as well as the unauthorized alteration of the warranty card without purchase certificate.

### **User instructions**

After purchasing the company's products, please carefully fill in the warranty registration card and affix the user's official seal. Please send the copy of warranty registration card and purchase invoice back to the user service department of the company, or entrust the seller to send it on behalf when purchasing the machine. If the procedures are incomplete, it can only be repaired without warrant.

## Mikrosize Distributors Worldwide

Coventry,UK /Warsaw,Poland/Burago di Molgora, Italy/Langgöns,Germany/  
Madrid, Spain/Istanbul,Turkey/Minsk,Belarus/Moscow , Russia /Sao Paulo, Brazil/  
Mexico City ,Mexico/Penang, Malaysia/Bangkok Thailand etc.....



## Anhui Mikrosize Precision Instrument Co.,Ltd

Factory Producing Add: N013 Shuiku Road Shatou, Changan Town, Dongguan, China.

International Trading Office: A-4035 RuiFeng Business Expo , Wuhu City, China.

Web: [www.mikrosize.com](http://www.mikrosize.com) Email: [mikrosize@mikrosize.com](mailto:mikrosize@mikrosize.com)

