



MPoli-230M Manual Grinding Polishing Machine

Instruction Manual



Anhui Mikrosize Precision Instrument Co.,Ltd

Add: A-4035 RuiFeng Business Expo, Wuhu City, China, 241000.

Web: www.mikrosize.com **Email:** mikrosize@mikrosize.com

Contents

| | |
|---|----------|
| One. Introduction | 1 |
| Two. Main Parameters..... | 1 |
| Three. Structure | 2 |
| Four. Installation and Usage | 3 |
| Five. Maintenance | 5 |
| Six. Packing List | 6 |

One. Introduction

MPoli-230M is a single-chip microcomputer controlled grinding and polishing machine, two discs are independently controlled. The shell is formed with ABS material, which is beautiful in appearance, anti-corrosion and durable. Strong large support chassis design ensures the precision rotary balance. It has stepless speed or four speed control and can change the rotational direction. The motor is DC brushless motor which has long service life and low noise and powerful motor brings strong power and efficient grinding and polishing experience. Spindle leak-proof design ensures the bearing without damage. It can adjust the cooling water tube direction for wet grinding. With washing function at the bottom of the grinding disc, it can prevent the accumulation and precipitation of grinding materials. Only need to change the abrasive paper and polishing cloth, it can complete various sample grinding, fine grinding and polishing process, which is the ideal sample preparation machine in the laboratory.

Two. Technical Parameters

| | |
|-------------------------|--|
| Model | MPoli-230M |
| Disc Diameter | 230mm |
| Abrasive Paper Diameter | 230mm |
| Speed | Stepless speed 50~1400r/min, |
| Rotational Direction | and Four speed 300, 600, 900, 1400r/min |
| Electromotor | Clockwise and Counterclockwise |
| Control and Display | DC brushless motor, 220V, 600W |
| Power Supply | Film key operation , Nixie tube display, With washing function |
| Dimensions | 220V, 50Hz, 8A |
| Net Weight | 757×660×330mm |
| Power Supply | 57kg |

Three. Structure

MPoli-230M model stepless speed regulation grinding and polishing machine uses frequency converter and DC brushless motor as power source; the motor mounted on electrical machinery seat is fastened on the machine body, drive the main shaft to rotate through o model Z920 triangle belt transmission (elasticity can be regulated), rubbing and polishing disc are set at the axle, rotate through screw transmission together with axle, after putting through the power in the switch, the grinding disc can be rotated steadily. Open the boiling water valve knob, the water promptly flow through water pipe and into the plate. Only need to operate the frequency conversion button, can realize the choices of different rotational speeds, it is extremely convenient to use.

Structural sketch:

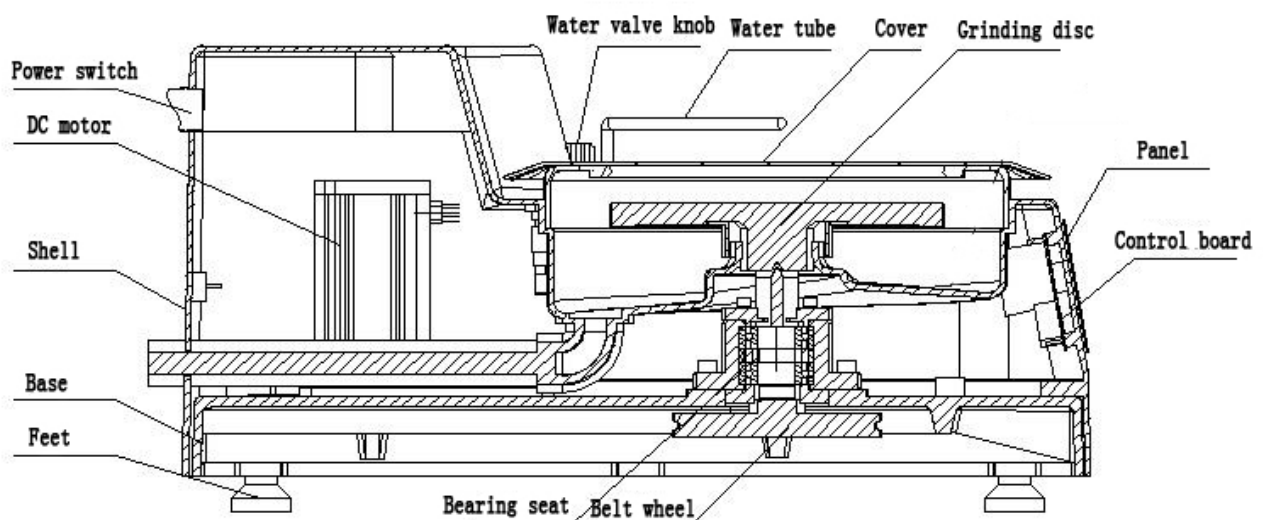



Four. Installation and Usage

1.Installment

- (1). Put this machine on the smooth work table and take down the packing plastic housing.
- (2). Inspect whether various components of the machine is complete or not, complete the clearing.
- (3). Put through the water inlet pipe and the discharge pipe, pay attention on the altitude of draining water place should be lower than the freeing port.
- (4). Insert the plug adapter into the electric outlet. Before the insertion, you should inspect whether the supply voltage is congruous, whether the ground connection of line is reliable.

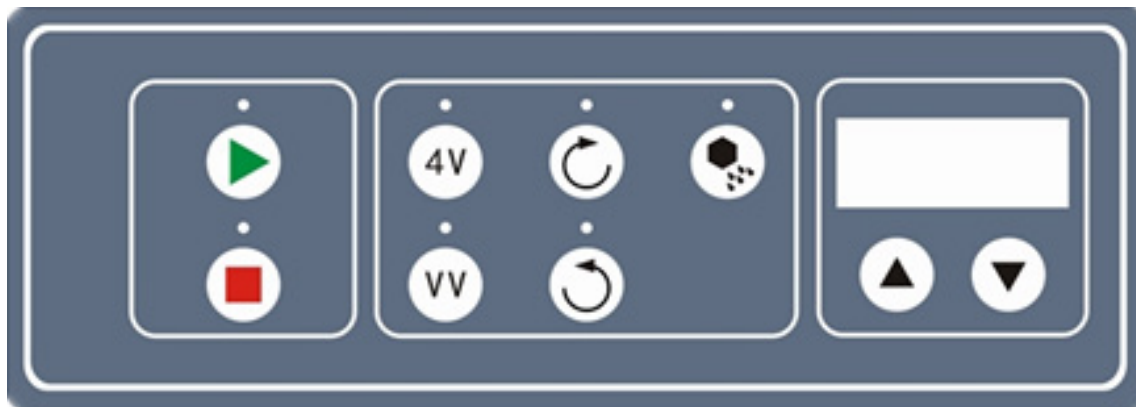
2.Introduce to the Main Functions of the Operation Panel



 is the start button, the disc operates after press it.

 is the stop button, the disc stop operating after press it.

 is the speed adjustment mode button, it becomes 4 speed adjustment mode after press it, divide 300, 600, 900, 1400r/min, the initial state is 4 speed adjustment mode and the speed is 300r/min.

 is the Speed increase button,(4V condition) press once to increase one speed.

 is the Speed decrease button,(4V condition) press once to decrease one speed.

 is the Stepless speed mode button, the disc speed becomes stepless speed after

Four. Installation and Usage

press it, each time increase or decrease 10r/min



is the increase speed button, (VV condition) press once to increase 10r/min.



is the decrease speed button, (VV condition) press once to decrease 10r/min.



is the forward direction button, the disc does clockwise rotation after press it, the initial state is forward direction.



is the reverse direction button, the disc does counterclockwise rotation after press it.



is washing key, press to rinse the dirt below the disc.

3.Usage

(1). At first, take down the plastic lid, change the abrasive disc or polishing disk (loading disk must do the cleaning work), and then loaded on plastic lid and click switch to required speed position, and then go on grinding and polishing work.

(2).Preliminary grinding: at first, put on abrasive disc, put water sand paper to the plate, open the water valve to make water continuously flows into the rotary abrasive disc, because of the effect of centrifugal force, the water in abrasive disc was thrown outside, i.e., the atmosphere will tightly pressure in water sand paper in the disk, but water should not be too big, only need to continuously flows into the plate.

(3). Polishing: put on the polishing plate, and at first, put a small amount of oil in the polishing plate, then stick polishing fabric paste in the disk, but must pay attention to the paste fabric must do vouchers to stick in the disk, and then drip on right amount polishing liquid or polishing paste and water on fabric surface to polishing work, to ensure the use of safe, general woolen cloth fabric is to use bonding method, all the accessories (ring) will stick fabric closely in the disk, but must be used after fabric wetting.

(4). When stop, should turn off the water valve after shutdown, avoid the water into the bearing inside, damage bearing and electric, influence the normal use of equipment.

Five. Maintenance

1. Not allowing to strengthen over-pressure to the sample while using, in case that frequency converter and motor overload and cause damage.
2. Do not allow to use already damaged abrasive paper and polishing fabric while using, so as not to influence the rubbing quality and cause accident.
3. Should do the daily clean work of maintaining well after using, remove the sediment timely in the blow down pass-way while not using, in order to make the water drain off unblocked, should close the plastics cover timely while not using, in case that the incidental falls into the plate, and influence the grinding quality thereafter.
4. This machine should change the lubricating grease in the bearing of the motor in time after long-term administration; generally change once every year.

Special note: If the motor doesn't rotate, such as that press RUN key the motor doesn't turn or the grinding disc doesn't rotate suddenly for the big resistance, then please turn off the power switch and power on system after one minute, and find out the cause of block, brushless motor phase lack or hall switch line broke or loose can also cause the not rotating of motor.

Electricity principle diagram:

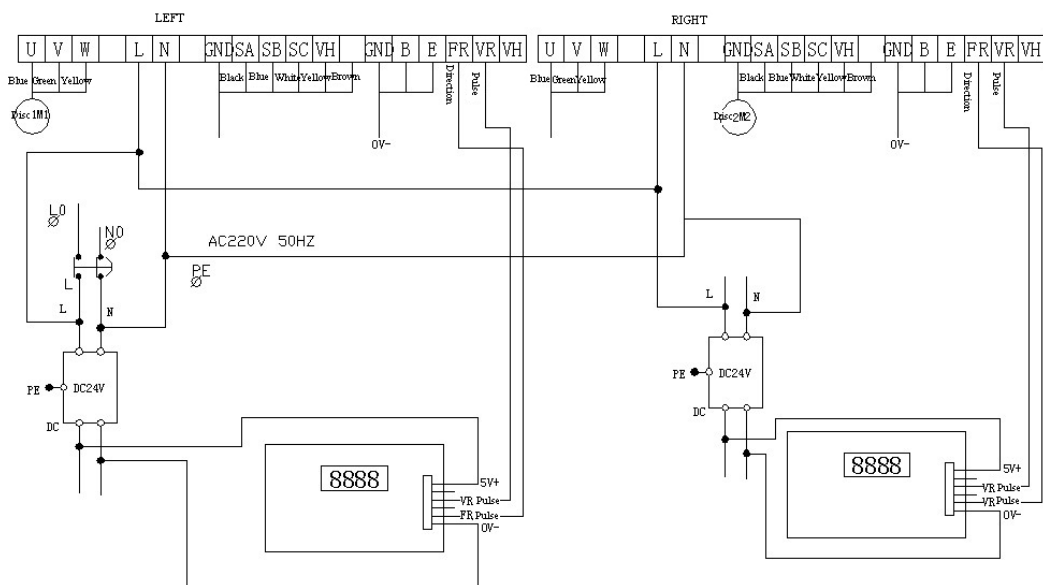

Six. Packing List

| Name | Specification | Qty |
|-----------------------------|---------------|--------|
| Machine Body | | 1 set |
| Grinding and Polishing Disc | 230mm | 2 pcs |
| Ferrule | | 2 pcs |
| Abrasive Paper | 230mm | 6 pcs |
| Polishing Cloth | 230mm | 2 pcs |
| Water Inlet Pipe | | 1 pc |
| Water Outlet Pipe | Φ32mm | 2 pcs |
| Water Inlet Filter Screen | | 1 pc |
| Usage Instruction Manual | | 1 copy |

Mikrosize Distributors Worldwide

Coventry,UK /Warsaw,Poland/Burago di Molgora, Italy/Langgöns,Germany/
Madrid, Spain/Istanbul,Turkey/Minsk,Belarus/Moscow , Russia /Sao Paulo, Brazil/
Mexico City ,Mexico/Penang, Malaysia/Bangkok Thailand etc.....



Anhui Mikrosize Precision Instrument Co.,Ltd

Factory Producing Add: N013 Shuiku Road Shatou, Changan Town, Dongguan, China.

International Trading Office: A-4035 RuiFeng Business Expo , Wuhu City, China.

Web: www.mikrosize.com Email: mikrosize@mikrosize.com

