



iBrin-62.5
Small Load Brinell Hardness Tester
Instruction Manual



Anhui Mikrosize Precision Instrument Co.,Ltd

Add: A-4035 RuiFeng Business Expo, Wuhu City, China, 241000.

Web: www.mikrosize.com **Email:** mikrosize@mikrosize.com

Introduction

▲ Please read this manual carefully before using this device to avoid improper damage.

▲ The text, illustrations, etc. in this manual are intended to provide a more detailed introduction to the operation of the hardness tester. Due to technological upgrades and differences in production batches, they may differ slightly from the hardness tester you actually operate. Please refer to the product you actually purchased for specific structure and configuration.

Contents

1.Product Introduction.....	1
2.Unboxing And Handling.....	4
3.Installation And Debugging	6
4.Apply	8
5.Maintenance And Upkeep.....	15
6.Packling List	17

1.Product Introduction

1.1Summary

Hardness is an important indicator of the mechanical properties of metal and alloy materials, usually referring to the ability of a material to resist the pressure of another harder object with a certain shape and size, and without residual deformation on its surface.

1.2.Experimental principle

The Brinell hardness test for metals involves using a hard alloy ball of a certain diameter and pressing it into the surface of the tested material with a specified test force (Figure 1a). After holding the test force for a specified time, the test force is removed, and the diameter of the indentation on the surface of the specimen is measured (Figure 1b) to calculate the Brinell hardness, which is then calculated using the following formula:

$$HBW = 0.102 \times 2F / \pi D (D - \sqrt{D^2 - d^2})'$$

Table 1 Symbols and Names

Symbol	Mame	Unit
D	Hard alloy balls	MM
F	Experimental force	N
d	Average diameter of indentation	MM
d1,d2	Indentation diameter measured in two perpendicular directions	MM
h	Indentation depth	MM
HBW	Brinell hardness	

1.Product Introduction

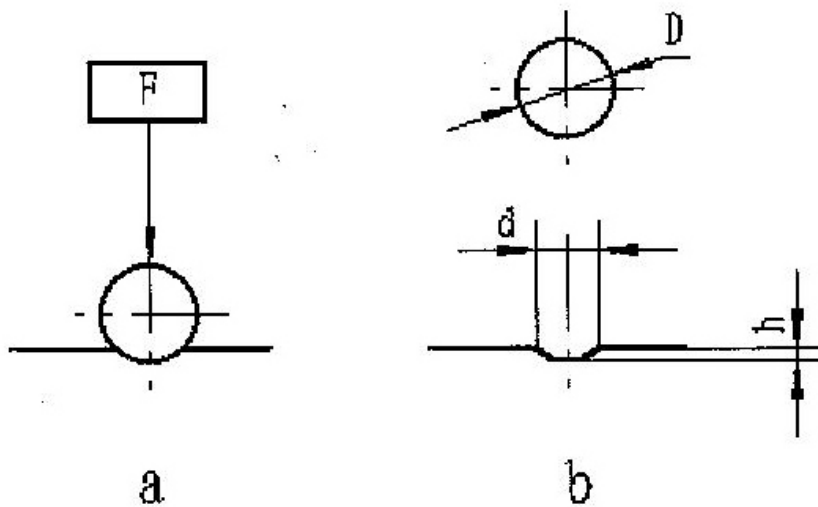

Figure 1 Principle diagram of Brinell hardness test

1.3.Characteristic

Automatically apply, maintain, and remove the main test force. Simple and convenient to operate, easy to master, high work efficiency, suitable for inspection of batch parts, with a wide range of applications, it is an important testing method for inspecting product quality and determining reasonable processing technology. Hardness tester is the most commonly used testing instrument for hardness testing, teaching, and research in production enterprises, universities, and research institutions.

1.4.Technical parameters

1. Test force: 1、 5、 6.25、 10、 15.625、 30、 31.25、 62.5kgf
2. Maximum height of the specimen: 175mm
3. Distance from indentation center to machine wall: 125mm
4. External dimensions of hardness tester: 320mm*580mm*620mm
5. Net weight of hardness tester: about65kg
6. Power supply: 220V 50HZ
7. Measurement system amplification factor: 50X 100X

1.Product Introduction

8.Transfer tower method: Automatic turret

1.5.Institutional components

This hardness tester mainly consists of loading and unloading components, turret components, test bench components, electrical components, etc.

During the experiment, the sample is placed on the workbench, and the hard alloy indenter is installed at the lower end of the spindle. When loading, the steel ball is pressed into the surface of the sample. After removing the test force, the diameter of the indentation is measured, and the hardness value of the sample is obtained from this. The hardness test must be carried out in accordance with the relevant provisions of the test method.

▲The hardness tester has a cast iron body and a screw seat is installed on the front of the body. The screw seat is equipped with a precisely matched screw, and the upper end of the screw is equipped with a replaceable workbench. The workbench rises and falls by the up and down movement of the screw, which is achieved by rotating the handwheel

▲The test force is applied to the specimen by a weight through a lever mechanism and a pressure head. The application of experimental force is automatically carried out by the lever loading and unloading component, which is driven by the rotation of the motor to lift and drop the lever mechanism on the camshaft, and transmitted to the pressure head by the main shaft.

▲The turret components consist of the turret motor, suspension shaft, main shaft, rotating head seat, and other components.

▲The variable load mechanism is composed of variable load handwheels, weights, weight brackets, cams, and other components.

▲The electronic control system consists of touch screen, main control board, photoelectric switch, power supply and other components.

The optical measurement system consists of a micrometer, an eyepiece, a reflector, a lighting lamp, etc. The machine has two types of objective lenses, 5X and 10X.

2.Unboxing and Handling

2.1.Preparation work

▲The working environment of the hardness tester should be dry, clean, and free of corrosive gases.

▲The working environment of the hardness tester should be free from external mechanical vibrations.

▲The working environment of the hardness tester should be between 10-30 °C.

▲The test bench (self provided) should be made of cement or metal as the substrate, with a certain degree of stiffness and strength, capable of bearing the hardness tester and its accessories. The table should be as shown in Figure 4 (the dimensions in the figure are for reference only). A hole with a diameter of 70 millimeters is provided for the screw to pass through, and the levelness of the entire tabletop should be within 0.2/1000.

▲Adequate space should be left around the hardness tester for necessary installation, maintenance, debugging, and other work.

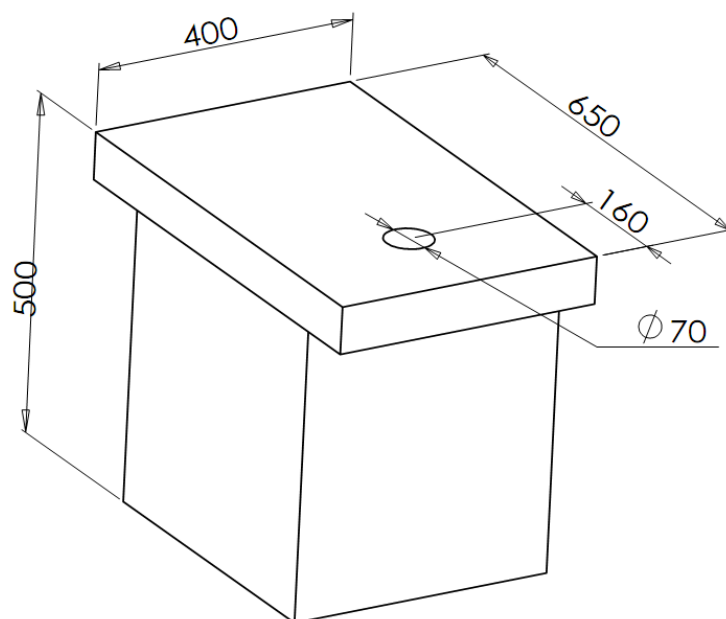

Figure 4 Schematic diagram of the test bench

2.Unboxing and Handling

2.2.Unboxing

1. Use tools to remove the packaging tape from the outer packaging box.
2. Use tools to remove the wooden screws that secure the box shell and base, and pull the box shell out upwards.
3. Take out the information bag and check it. The bag should contain the user manual (including packing list and certificate of conformity).
4. Check the items in the attachment box and verify if they match the packing list.
5. Use a wrench to remove the four anchor bolts that secure the hardness tester to the base of the packaging box.

2.3.Handling precautions

▲ Do not attempt to handle the hardness tester alone, as the equipment is heavy and improper operation can cause damage to the hardness tester and personal injury. Therefore, two or more experienced operators are required to move this device.

▲ When transporting the hardness tester, the inclination of the axis between the indenter and the screw in the vertical direction shall not exceed 15 °.

▲ When transporting the hardness tester, the contact position between the operator and the hardness tester is limited to the outer surface of the machine body. Do not touch other surfaces or other parts of the hardness tester to avoid affecting the accuracy of the machine.

▲ When transporting the hardness tester, it should be lifted and dropped gently to avoid causing collisions and impacts.

3.Installation and Debugging

Before installing and adjusting the hardness tester, prepare a wrench, level, workbench, etc.

appearance of hardness tester host

name of each component:

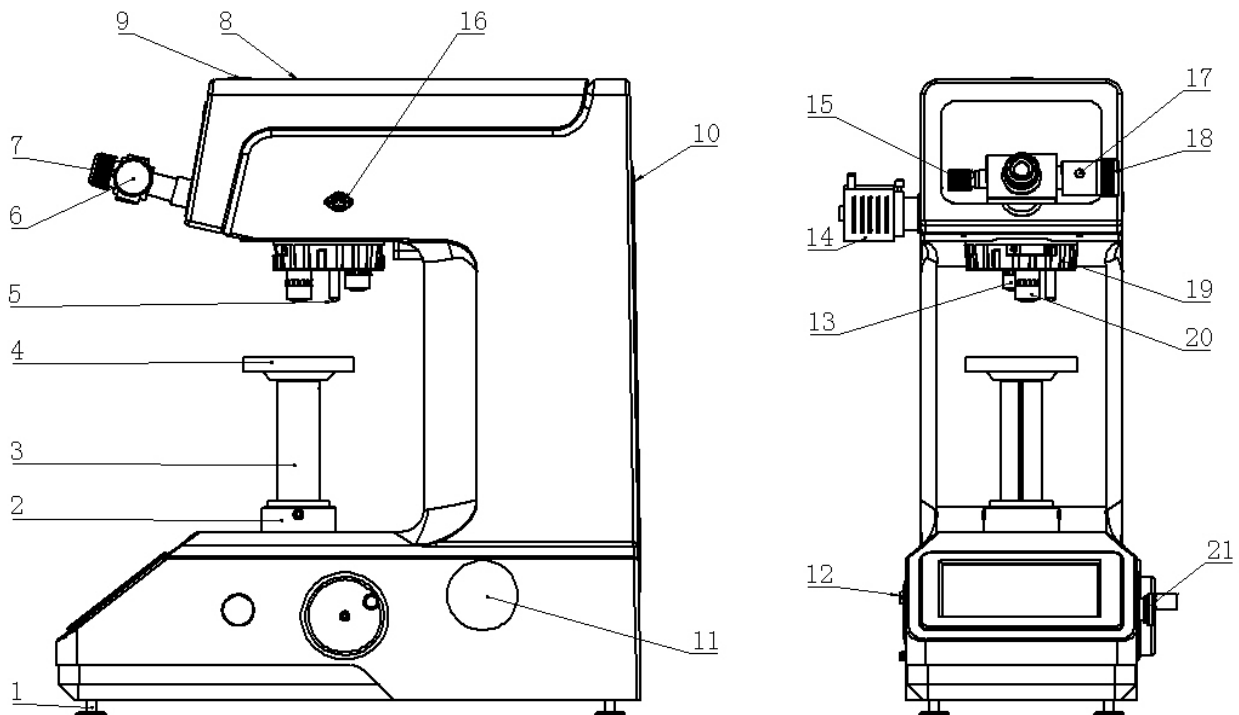

Figure (2)

Figure 3.1 Appearance of the hardness tester host

Table 3.1 Names of each component

1.Adjusting screws	8.Upper cover	15.Left drum wheel
2.Lifting seat	9.Camera cover	16.Round socket
3.Lift shaft	10.Rear cover	17.Measuring button
4.Test table	11.Hand wheel	18.Right drum
5.Indenter	12.Power switch	19.Turret
6.Eyepiece	13. 5x objective lens	20.10x objective lens
7.Eye cover	14.Light source	21.Emergency stop button

3. Installation and Debugging

3.1. The installation steps are as follows:

1) Remove the four nuts at the bottom of the box, lift and move the box away, and

take out the accessory box;

2) Lift the bottom plate and use a wrench to unscrew the two M10 bolts under the bottom plate, separating the hardness tester from the bottom plate.

3) Place the hardness tester on a stable workbench and open a hole in an appropriate position on the workbench (Figure 1) to ensure that the screw works properly;

4) Take out the adjustment screw (1) from the accessory box and screw it to the bottom of the main body (Figure 2), and adjust it to the horizontal position;

5) Rotate the rotary wheel (2) so that the screw (3) can smoothly pass through the hole opened by the dedicated workbench. The specific size of the workbench hole is:

6) Open the upper cover (8), remove all the ribbons attached to the lever, and then cover the upper cover.

7) Take out the test bench (4) from the accessory box and place it in the hole of the screw (3). Insert one end of the eyepiece (6) into the eyepiece tube insert the eyepiece wire plug into the circular socket (16).

Install the micrometer and connect it to the equipment

Connect the power cord, turn on the power switch, and the objective lens will automatically rotate above the workbench.

4. Apply

4.1. Preparation work before the experiment

1) Sample preparation: The surface of the sample should be smooth and flat, without oxide layer, electroplating layer, and surface defects, and should be clean and free of oil and dirt. The surface roughness Ra of the sample should not exceed 1.6 microns. When preparing the sample, the surface of the sample should not be affected by heat or work hardening to change its hardness. The parallelism between the test surface and the supporting surface should be ensured.

2) The selection, installation, and sample requirements of the indenter should meet:

Ruler table

Ruler	load (kg)	Indenter (mm)
HBW1/1	1	1
HBW1/5	5	1
HBW2.5/6.25	6.25	2.5
HBW1/10	10	1
HBW2.5/15.625	2.5	15.625
HBW1/30	1	30
HBW2.5/31.25	31.25	2.5
HBW5/31.25	31.25	5
HBW2.5/62.5	62.5	2.5
HBW5/62.5	62.5	5

A. Installing the indenter

a) Select the corresponding indenter according to the ruler.

b) Install the pressure head and press the pressure head fastening screw onto the flat part of the fixing rod to complete the installation.

B. Select test scale: According to the test requirements, select a measurement scale on the LCD screen

4. Apply

The sample should meet the following requirements:

a) The sample should be made with a smooth surface, making the edges of the indentation clear enough to ensure the accuracy of indentation measurement. The surface of the sample should be free of oxide layer, oil stains, and surface defects.

b) The parallelism between the test surface and the supporting surface, as well as the level of the test surface, should be ensured to ensure that the load is perpendicular to the surface of the specimen.

c) The thickness of the specimen shall not be less than 10 times the diameter of the indentation. If the relevant technical conditions specify otherwise, its thickness shall not be less than 8 times the depth of the indentation, and the depth of indentation shall be determined

$$h = \frac{D - \sqrt{D^2 - d^2}}{2} \text{ (mm)}$$

If there are deformation marks on the edges and back of the sample after the test, the test is invalid. Smaller steel balls and corresponding loads should be selected for retesting.

d) The distance between the center of the indentation and the edge of the specimen should not be less than 2.5 times the diameter of the indentation, and the distance between two adjacent indentation centers should not be less than 3 times the diameter of the indentation. For soft metals, this distance should also be appropriately increased.

e) The size of the indentation diameter after the test should be $0.24D < d < 0.6D$. If the above conditions are not met, the test results are considered invalid, and the corresponding test force should be selected for retesting.

4. Apply

f) During the test, it is necessary to ensure that the axis of the indenter is perpendicular to the test plane of the specimen or specimen. During the test, the loading and unloading of the test force should be stable, without impact or vibration.

g) The diameter of the indentation should be measured from two perpendicular directions and the arithmetic mean should be taken. The difference between the two diameters of the indentation and the smaller diameter should not exceed 1%.

C. Turn on the power switch, the host will automatically reset to the unloading state, and the touch screen will display the startup interface. As shown in the following figure

4.2.Panel Introduction Description



Figure 4-1

4. Apply

- 1) Display date and time: Long press the time and date position to pop up a modification dialog box, which allows you to modify the date and time.
- 2) Hardness display area: displays the measured hardness value, displaying the upper and lower limits of the testing force and hardness.
- 3) Hardness conversion area: Click to enter the hardness conversion selection and select the hardness scale that needs to be converted. And display the converted hardness value.
- 4) Ruler selection area: Click to enter the selected test ruler.
- 5) Load holding time: Click to enter the set load holding time and display the current load holding time during operation.
- 6) Light adjustment: Adjust the brightness of the light by adjusting the (+) (-) on both sides of the value.
- 7) Measurement data: Set the number of measurements and display the average, maximum, and minimum values of the measurements. Click on the icon to enter the measurement data list, which displays the current measured hardness value.
- 8) Measurement value: Display the measured indentation diameter size and display the numerical value.
- 9) Data Query: Query saved historical data, click to enter, and you can search and print historical data.
- 10) Save: After the test data is completed, press the save button to save the current data in the historical data.
- 11) Print: After the test data is completed, press the print button to print the data.

4. Apply

12)5X: Press the 5x objective button to convert the objective to 5x and rotate the turret to 5x.

13)10X: 10x objective button, convert the objective to 10x, and rotate the brick tower to 10x.

14)Start: Press the start button. After pressing the start button, this button will display stop. After starting the experiment, press stop to stop the experiment. After loading and resetting, the brick tower will also reset.

4.3. Formal testing

After the above installation adjustments, the hardness tester can be used for hardness testing. The steps are:

1. Wipe the supporting surface of the specimen clean, place it stably on the test bench, rotate the lifting handwheel to lift the specimen up, pay attention to observing the micrometer. When the image reaches the clearest, stop rotating, click the start button, and the rotating head will automatically rotate. When the pressure head reaches the working position, the loading motor will start running and automatically complete the loading, holding, and unloading processes. Click the stop button during the loading process, and the loading device will interrupt the current operation and immediately return to unloading. After unloading is completed, the rotating head will rotate in the opposite direction, and the lens will enter the working position.

2. Observing the micrometer image, if there are any unclear situations, you can rotate

the handwheel to achieve the clearest image.

4. Apply

4.4. The use of micrometers:

Rotate the lifting handwheel and observe the micrometer eyepiece until clear indentations are visible on the surface of the specimen. Rotate the micrometer eyepiece and adjust the reticle markings to be clear.

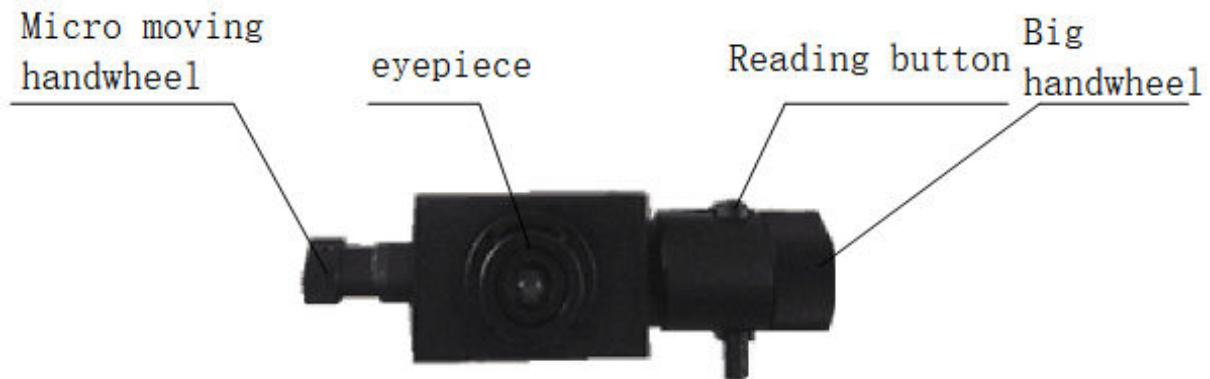

Figure F

As shown in Figure F, observe through the eyepiece, rotate the two handwheels, move the two lines in the micrometer, wait for the two lines to be tangent, and long press the reading button key to reset to zero, so that d_1 The value of d_2 is reset to zero and enters the counting state.

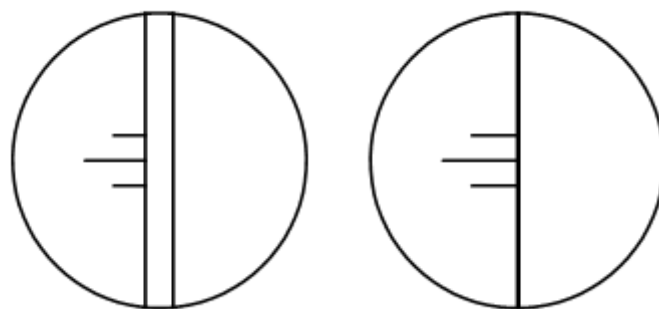

Figure G

Attention: This operation does not need to be performed at every point of measurement, but it must be performed after startup, otherwise the hardness value will be calculated incorrectly!

4. Apply

Observe the test indentation through the eyepiece. If it is not clear, rotate the lifting handwheel for fine adjustment until it is clear. Rotate the micro handwheel to make one of the micrometer's markings tangent to one side of the indentation; Rotate the large handwheel to make the other engraved line tangent to the other side of the indentation, as shown in Figure H;

Press the reading button once, and the display screen will display an indentation diameter $d_1 = x.xxx$;

Rotate the micrometer clockwise by 90° , repeat the above steps, and then press the reading button. The display screen will display the diameter of the indentation in the other direction, $d_2 = x.xxx$, and the measured value will also be displayed

The Brinell hardness value of the sample.

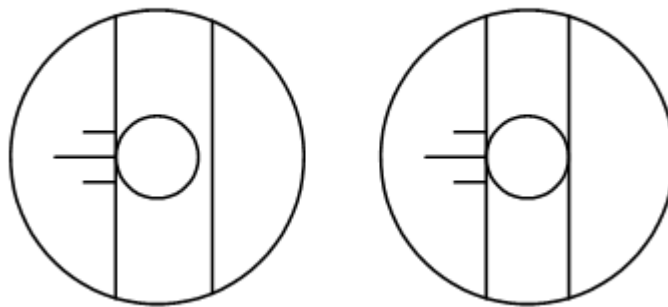

Figure H

5. Maintenance and Upkeep

5.1. Cleaning and lubrication

When the hardness tester is not used for a long time, the machine should be covered with a dust cover.

Regularly inject an appropriate amount of engine oil into the contact surface between the screw and the handwheel. (twice a month)

5.2. Operation precautions

1. Installation of pressure head: Various specifications of pressure heads are composed of three parts: fixed rod, fixed nut, and ball. Before installation, the fixed rod spherical groove and ball must be rinsed with acid free gasoline and wiped clean. Apply a small amount of acid free Vaseline oil to the fixed rod spherical groove, install the ball, and then tighten the fixing nut. During the experiment, it is necessary to regularly check whether the ball is loose inside the pressure head. If the ball is found to be loose, the experiment is invalid.
2. During the loading, holding, and unloading processes, the rotating head must not be rotated to avoid malfunctions.
3. Power supply voltage selection: Use 220V voltage according to regulations and make sure to connect the ground wire properly.
4. Adjustment of test force retention time: If the hardness is the same when testing multiple samples, there is no need to adjust the test force retention time after it is set; If the hardness is different, readjust the holding time according to regulations.
5. Sample temperature: The sample temperature during the test should be maintained at room temperature. In special circumstances, the temperature of black metals should not exceed 100 °C, and non-ferrous metals should be strictly maintained at room temperature.

5. Maintenance and Upkeep

5.3. Troubleshooting

troubleshooting guide

When a hardness tester malfunctions, the following content can help you speculate on the problem and recommend troubleshooting methods. If the problem cannot be solved, please do not disassemble the hardness tester without authorization. Please contact our company's after-sales service department.

Table 5 Troubleshooting Guidelines

Faults and phenomena	reason	Exclusion method
Screw lifting block	Rust or debris	Remove debris from the screw and handwheel, and add lubricating oil
Inaccurate hardness value	Indentation distance	Is the distance between the centers of the two indentations too close
		Is the distance between the indentation and the edge of the specimen too close
	Adjustment issues	The micrometer is not fully inserted
		No reset during startup
		Incorrect ruler selection
	Problems with the sample	Is the test surface of the sample perpendicular to the test force
		Poor surface smoothness during sample testing
		Is the thickness too small
	Environmental reasons	Is there a mechanical vibration source around
		The ambient temperature should be maintained at 10-30 °C
other		Calibration of hardness tester using random standard hardness blocks

6. Packing List

For Small Load Brinell Hardness Tester

Model: iBrin-62.5

No.	Descriptions	Specification	Quantity
1	Brinell Hardness Tester		1 set
2	Large flat anvil		1 pc.
3	Small flat anvil		1 pc.
4	V-notch anvil		1 pc.
5	Hard alloy indenter	Φ1mm	1 pc.
6	Hard alloy indenter	Φ2.5mm	1 pc.
7	Brinell standard block		2 pcs
8	Accessory box		1 pc.
9	10×digital display micrometer eyepiece		1 pc.
10	Fuses		1 pc.
11	Horizontal adjustment screw		4 pcs.
12	Internal hexagonal wrench		1 pc.
13	Dust cover		1 pc.
14	Screwdriver		1 pc.
15	Power cord		1 pc.
16	Operation Instruction		1 share
17	Certificate		1 share
18	Packing list		1 share

Mikrosize Distributors Worldwide

Coventry,UK /Warsaw,Poland/Burago di Molgora, Italy/Langgöns,Germany/
Madrid, Spain/Istanbul,Turkey/Minsk,Belarus/Moscow , Russia /Sao Paulo, Brazil/
Mexico City ,Mexico/Penang, Malaysia/Bangkok Thailand etc.....



Anhui Mikrosize Precision Instrument Co.,Ltd

Factory Producing Add: N013 Shuiku Road Shatou, Changan Town, Dongguan, China.

International Trading Office: A-4035 RuiFeng Business Expo , Wuhu City, China.

Web: www.mikrosize.com Email: mikrosize@mikrosize.com

