



MBrin-3000A
Fully Automatic Brinell Hardness Tester
Instruction Manual



Anhui Mikrosize Precision Instrument Co.,Ltd

Add: A-4035 RuiFeng Business Expo, Wuhu City, China, 241000.

Web: www.mikrosize.com **Email:** mikrosize@mikrosize.com

Contents

1.Overview	1
2.Introduction to Hardness Testers	2
3.Main technical parameters.....	4
4.External structure of the hardness tester	5
5.Working conditions of a hardness tester	6
6.Unpacking and installation	6
7.Interface Introduction and Usage.....	7
8.Formal Test Operations	12
9.General Troubleshooting.....	12
10.Maintenance and Precautions	13
11.Appendix	14
12.Packing List	17

1.Overview

The Brinell hardness test for metals uses a cemented carbide ball of a certain diameter, which is pressed into the surface of the material being tested with a specified test force. After holding for a specified time, the test force is removed, and the diameter of the indentation on the sample surface is measured to calculate the Brinell hardness, which is then calculated using the following formula:

$$HBW = 0.102 \times \frac{2F}{\pi D} \left(D - \sqrt{D^2 - d^2} \right)$$

In the formula:

F-----Test force N;

D-----Ball diameter mm;

d-----Average diameter of indentation mm;

HBW---Brinell hardness measured using a cemented carbide ball indenter.

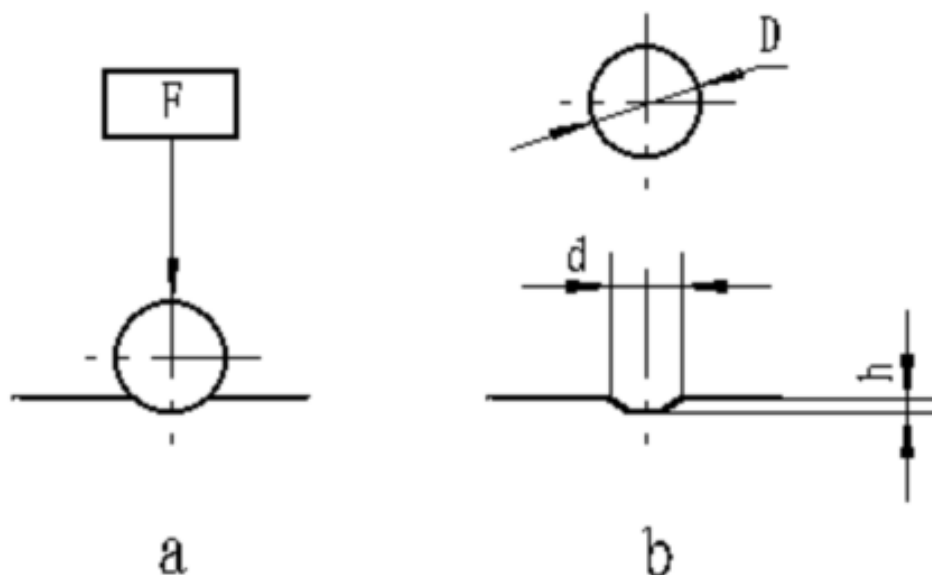

For example, 216HBW10/3000/10, when a cemented carbide ball with a diameter of 10mm is used to hold the test force of 29.42KN (3000kgf) for 10 seconds and the hardness is measured to be 216, its Brinell hardness is represented by the symbol HBW, and so on.

2.Introduction

The fully automatic four-indenter digital display Brinell hardness tester features a cast iron housing, ensuring high rigidity and measurement accuracy. Its precision structural design, with test force application directly controlled by a force sensor, results in a compact structure and smooth, accurate application and removal of test force. Electrically, the CPU controls the testing process, with automatic switching between the objective lens and indenter. The switching positioning utilizes a combination of mechanical and electronic mechanisms, enhancing positioning accuracy. A built-in touchscreen and microcomputer make parameter setting and result display more intuitive and convenient, avoiding eye strain and fatigue from the light source, and reducing measurement errors. After selecting the appropriate scale, the hardness tester automatically selects the indenter and objective lens, the platform automatically rises, and after applying the test force, it automatically returns to the focusing plane, clearly displaying the indentation and automatically measuring, achieving full automation of Brinell hardness measurement.

▲ This instrument has 12 levels of test force and 16 Brinell hardness test scales, and is suitable for testing various metallic and non-metallic materials.

▲ It features four ball indenters and two sets of objective lenses, eliminating the hassle of frequently changing indenters when measuring different samples, and preventing damage to the indenters due to mismatch between the indenter and the test force. The optical structure is robust and the magnification is high, making the surface to be observed very clear.

▲ The automatic lifting platform adopts a precision structure and has high stability. It automatically rises after the measurement starts and automatically

2.Introduction

returns to the focusing surface after the test force is applied, so as to directly perform the measurement and realize the function of one-button automation.

▲The hardness tester and microcomputer are integrated, equipped with a Windows system, and have all the functions of a computer.

▲Built-in CCD image automatic measurement system, touch screen operation display, can preset test force holding time, adjust light source intensity, display the measured indentation length, hardness value, hardness value measurement range, number of measurements, etc.

▲The software system also includes functions such as calibration, manual fine-tuning, and setting upper and lower limit alarms to ensure measurement accuracy.

▲It has a scale conversion function, which allows you to select the conversion value between hardness scales.

▲The hardness test results can be generated into WORD or EXCEL reports, which can be saved directly or printed out by an external printer for easy reference and research by users in the future.

▲The instrument is equipped with a USB interface, a VGA interface, and a network port, allowing it to be connected to external networks and other devices, giving users more optional functions.

It is suitable for hardness testing of materials such as cast iron, steel, non-ferrous metals and soft alloys, and also suitable for hardness testing of certain non-metallic materials such as hard plastics and bakelite.

3.Main Technical Parameters

Name	Specification
Test force	294.2N(30kgf) 306.45N (31.25kgf) 612.9N (62.5kgf) 、 980.7N (100kgf) 、 1226N (125kgf) 、 1839N (187.5kgf) 、 2452N (250kgf) 、 4903N (500kgf) 、 7355N (750kgf) 、 9807N (1000kgf) 、 14710N (1500kgf) 、 29420N (3000kgf)
Test scale	HB 10/3000、 HB 10/1500、 HB 10/1000、 HB 5/750、 HB 10/500、 HBW 10/250、 HB5/250、 HB 2.5/187.5、 HB 10/125、 HB5/125、 HB10/100、 HB 5/62.5、 HB2.5/62.5、 HB5/31.25 、 HB2.5/31.25、 HB1/30
Loading method	Automatic lifting, loading, dwelling, unloading, and automatic measurement
Maximum allowable height of specimen	280mm
Deep throat	200mm
Dwelling time	0-99S
Indenter and objective lens switching	Automatic
Objective lens	1X、 2X
Optical path conversion	Automatic
Indenter diameter(mm)	Φ1、 Φ2.5、 Φ5、 Φ10 Installed on the same turret
Indentation image measurement method	Automatic measurement
Data output	Output reports in WORD and EXCEL formats
Light source	LED
External dimensions mm(L×W×H)	1000×595×350
Power supply voltage	AC 220V±5%,50~60 Hz

4.External Structure

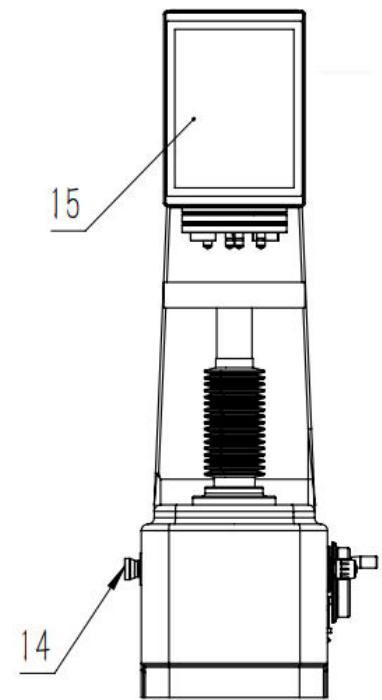
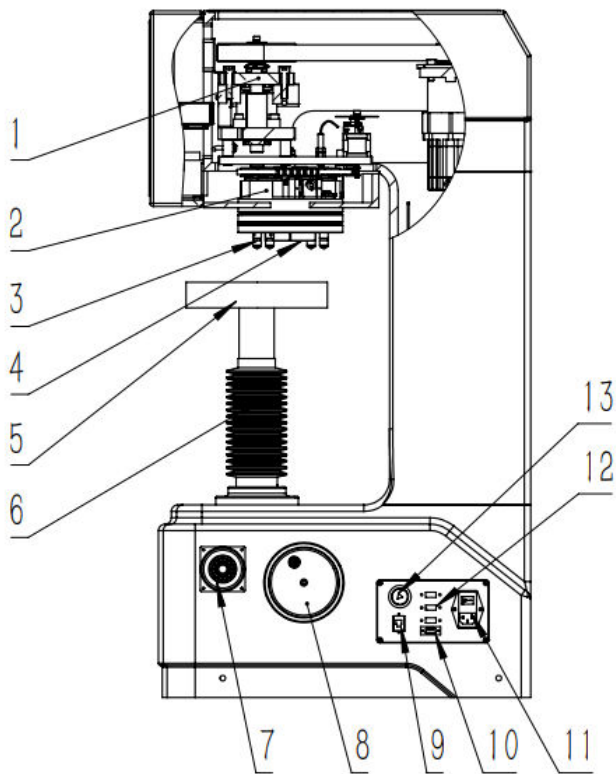

1.Loading components

2.Six-position turret

3.Indenter

4.Objective lens

5.Workbench

6.lifting screw assembly

7.Handle joystick

8.Handwheel

9.Network cable port

10.232 port

11.Power socket

12.USB port

13.Metal button

14.Emergency stop button

15.Display panel

5. Working Conditions

1. Within the room temperature range of 10~30°C.
2. The indoor relative humidity should not exceed 65%.
3. Place it horizontally on a stable foundation. There should be no vibration or corrosive media nearby.
4. Connect using a regulated power supply with good grounding.

6. Unpacking and Installation

1. Cut the packing tape on the box.
2. Unscrew the screws on the middle metal sheet on both sides of the bottom of the packaging box.
3. Lift the wooden crate upwards to see the instrument, then remove the accessory box and dust cover.
4. Use a fork wrench to unscrew the four external hex bolts under the wooden support.
5. Open the accessory box and install the four handles onto the screw holes on the outside of the bottom of the instrument.
6. Lift the hardness tester and place it on a sturdy workbench (a workbench height of 450mm is recommended).

Holes need to be made in the work surface; the following design is recommended:

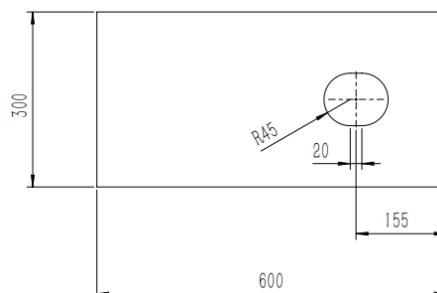

7. Take out the power cord, connect the power supply, and plug the dongle into the USB port of the hardness tester.

7.Interface Introduction and Usage

Main interface:

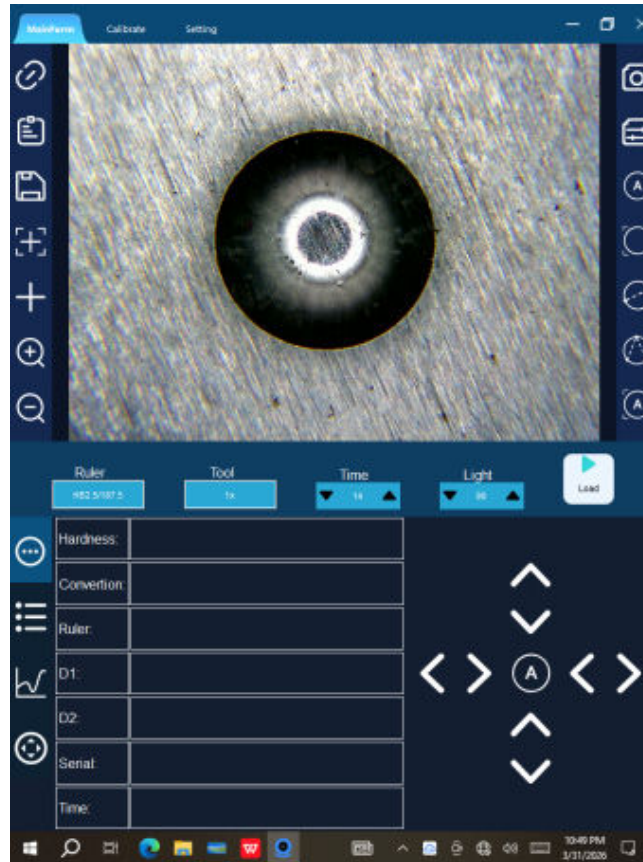

Click "Ruler" , and the following interface will appear. Select the desired test scale and click OK.

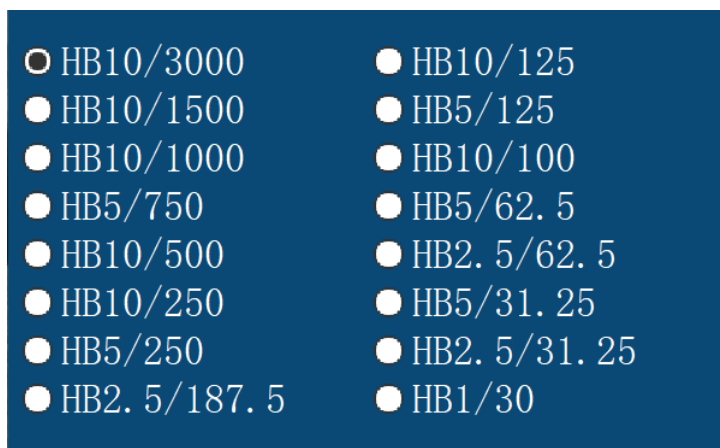

Click "Tool" to select either the indenter or the objective lens, rotating it to the current working position.

Click "Time" to change the dwelling time.

Click "Light" to change the LED light brightness.

7.Interface Introduction and Usage



▲ Device communication: Communicate between the software and the hardness tester host.

▲ Export Report: Export current data report.

▲ Save image: The captured images can be saved to a computer.

▲ Crosshair Reset: The crosshairs in the image area can be dragged to any position on the screen. Clicking "Reset" will return the crosshairs to the center position.

▲ Show and hide crosshairs: You can toggle the display of the crosshairs by clicking this button.

▲ Image magnification: Zoom in on the image.

▲ Image reduction: Reduce the image size.



▲ Real-time image acquisition and fixed image buttons: Displays a live image; clicking it will pin the image to the display area.

▲ Camera parameter settings: After clicking to enter, you can adjust various parameters of the camera.

▲ Automatic measurement: The automatic measurement function can fix the image and automatically measure the indentation on the fixed image.

▲ Manual measurement of the switch box: Cut the upper and left tangent lines to the edge of the indentation, then hold down the left mouse button (do not release) and cut the right and lower tangent lines to the other two edges of the indentation. Release the mouse button to get the hardness value.

7.Interface Introduction and Usage

▲ Manual measurement of two-point circles: Click on a point on the edge of the indentation (do not release), then release the mouse on the other edge at the corresponding diameter position to get the hardness value.

▲ Three-point circle manual measurement: The hardness value can be obtained by marking three points at any position on the edge of the indentation.

▲ Automatic area measurement: Suitable for situations where there are multiple indentations in the display area.

▲ Hardness fine-tuning function: If the measured hardness value does not match the indentation, you can select the direction of the mismatch for fine adjustment, either increasing or decreasing the value. (The image below)



Calibration interface:

First, use the camera to find a standard indentation on the standard block. Select the measurement scale, click automatic measurement, and measure the indentation. Click the calibration button to enter the calibration interface, enter the correct standard hardness value into the standard block hardness, click calculate coefficient, and then click calibrate.

7.Interface Introduction and Usage

The screenshot shows a software application window titled "Calibrate" with three main sections:

- Calibrate Info:** Contains four input fields: "DTool" with value 2.5, "Pressure" with value 187.5, "DImage" with value 0, and "CalibType" with a dropdown menu set to "HardnessCalib".
- Calibrate A:** Contains a "coef" field with value 0.00623181 and a "Hardness" field. Below these fields are two buttons: "Calculate" and "Calibrate".
- Calibrate B:** Contains a "coef" field with value 0.0030997 and a "Hardness" field. Below these fields are two buttons: "Calculate" and "Calibrate".

The Windows taskbar is visible at the bottom of the window, showing the time as 10:54 PM on 3/31/2025.

Calibration A : 1X Objective Calibration.

Calibration B : 2X Objective Calibration.

7.Interface Introduction and Usage

Settings interface:

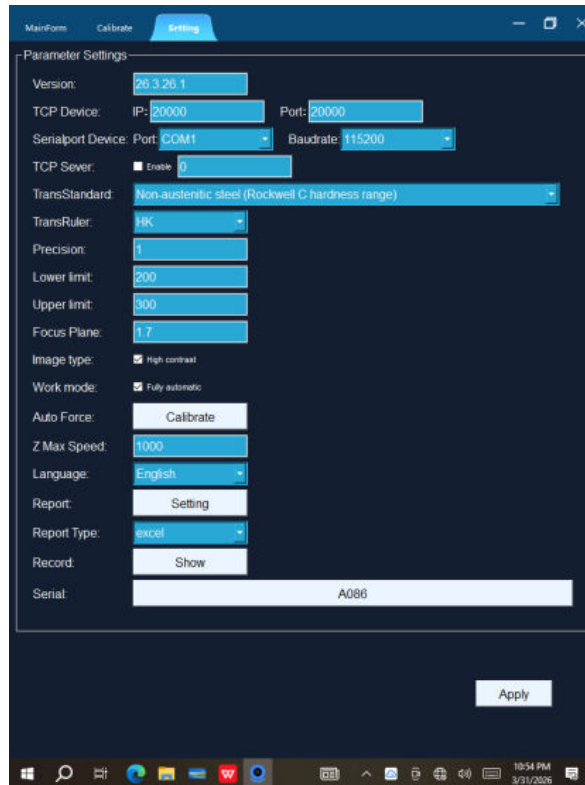

- ▲ TransStandard:Selectable conversion materials.
- ▲ TransRuler:Select the desired hardness conversion scale.
- ▲ Upper limit of hardness, lower limit of hardness: Enter the range of hardness values for the workpiece.
- ▲ Focus Plane:The position of the focal plane can be adjusted.
- ▲ Auto Force:Unauthorized personnel are not permitted to access this interface.
- ▲ Z Max Speed:Do not modify.
- ▲ Language:Supports switching between Chinese and English.
- ▲ Report:Can configure the table's header information.
- ▲ Record:Can filter the data to be exported.
- ▲ Report type:Can choose to export reports in Word, Excel, or PDF format.
- ▲ Serial:Change the Serial Number of the Detected Product.

8. Formal Test Operations

Place the specimen to be tested securely on the worktable. Select the desired test scale on the touchscreen, then tap the "Start" button. The turret will automatically rotate to position the corresponding indenter for the selected test scale; subsequently, the worktable will automatically ascend until the specimen's surface makes contact with the indenter, at which point the ascent will halt. The loading, dwell, and unloading phases will then be executed. Once the loading test is complete, the worktable will descend to the measurement position, and the turret will rotate to align the optical objective lens for automatic measurement. The test results will be displayed on the screen, marking the conclusion of the test cycle.

Note: The machine must be calibrated using a standard Brinell hardness block before each test.

9. General Troubleshooting

- No Display Upon Power-On: Verify whether the power switch is turned on, the power fuse has blown, and the power cable is securely connected. Check if the power outlet is supplying 220V voltage.
- No Display Upon Power-On: Verify whether the power switch is turned on, the power fuse has blown, and the power cable is securely connected. Check if the power outlet is supplying 220V voltage.
- Test Force Error: Use a force gauge to verify whether the test force complies with standard requirements.
- If you discover any other malfunctions, please contact the manufacturer or supplier.

10. Maintenance and Precautions

- After use, the machine should be covered with a dust cover to prevent dust from entering the interior.
- For long-distance transport, the original packaging should be restored.
- Exercise extreme care and precision when installing or removing the indenter and indenter cap to ensure that the tungsten carbide ball remains free from contamination and damage, and that the mounting surface is clean and free of debris. If the indenter is to remain unused for an extended period, it should be removed and stored securely.
- The surfaces of the test stand and the standard block must be clean, free of contaminants, scratches, and nicks. After use, apply rust-preventive oil for storage.
- The working environment conditions shall be free from vibration and corrosive media.
- The ground wire of this unit must be reliably grounded to prevent accidents.
- The verification and calibration of hardness testers shall be conducted in accordance with relevant national standards or regulations.
- This unit is a precision instrument; please do not attempt to disassemble or adjust any internal components yourself. Should any anomalies occur, please contact our company for repair and service.

11. Appendix

Correspondence Table of Test Force and Indenter Diameter:

Type	Brinell Hardness Value Range HBS(W)	Specimen thickness (mm)	0.102F/D	Ball Diameter D(mm)	Force F KN(kgf)	Dwell time (S)
Ferrous Metals	140~450	6 ~ 3 4 ~ 2 < 2	30	10.0 5.0 2.5	29.42 (3000) 7.355 (750) 1.839 (187.5)	12
	< 140	> 6 6 ~ 3	10	10.0 5.0	9.807 (1000) 2.452 (250)	12
Non-ferrous metals	> 130	6 ~ 3 4 ~ 2 < 2	30	10.0 5.0 2.5	29.42 (3000) 7.355 (750) 1.839 (187.5)	30
	36~130	9 ~ 3 6 ~ 3	10	10.0 5.0	9.807 (1000) 2.452 (250)	30
	8~35	> 6	2.5	10.0	2.452 (250)	60

11. Appendix

Selection of Minimum Specimen Thickness for Brinell Hardness Testing:

Average Indentation Diameter(d)	Minimum specimen thickness			
	Ball Diameter			
	D=1	D=2.5	D=5	D=10
0.2	0.08			
0.3	0.18			
0.4	0.33			
0.5	0.54			
0.6	0.8	0.29		
0.7		0.4		
0.8		0.53		
0.9		0.67		
1		0.83		
1.1		1.02		
1.2		1.23	0.58	
1.3		1.46	0.69	
1.4		1.72	0.8	
1.5		2	0.92	
1.6			1.05	
1.7			1.19	
1.8			1.34	
1.9			1.5	

11.Appendix

2			1.67	
2.2			2.04	
2.4			2.46	1.17
2.6			2.92	1.38
2.8			3.43	1.6
3			4	1.84
3.2				2.1
3.4				2.38
3.6				2.68
3.8				3
4				3.34
4.2				3.7
4.4				4.08
4.6				4.48
4.8				4.91
5				5.36
5.2				5.83
5.4				6.33
5.6				6.86
5.8				7.42
6				8

12.Packing Lis

Name	Specification	Qty.
Instrument Main Body		1 set
Large Plane Test Table		1 pc
Small Plane Test Table		1 pc
V-shaped Test Table		1 pc
Carbide Ball Indenter	Φ10	1 pc
Carbide Ball Indenter	Φ5	1 pc
Carbide Ball Indenter	Φ2.5	1 pc
Carbide Ball Indenter	Φ1	1 pc
Standard Brinell Hardness Block		2 pcs
Anti-dust Cover		1 pc
Usage Instruction Manual		1 pc
Power Cable		1 pc
Dongle		1 pc
Software USB Drive		1 pc
Fuse 2A		2 pcs
Brinell IndentationMicroscope 20X		1 pc
Inner Hexagon Spanner		1 pc
Packing List		

Mikrosize Distributors Worldwide

Coventry,UK /Warsaw,Poland/Burago di Molgora, Italy/Langgöns,Germany/
Madrid, Spain/Istanbul,Turkey/Minsk,Belarus/Moscow , Russia /Sao Paulo, Brazil/
Mexico City ,Mexico/Penang, Malaysia/Bangkok Thailand etc.....



Anhui Mikrosize Precision Instrument Co.,Ltd

Factory Producing Add: N013 Shuiku Road Shatou, Changan Town, Dongguan, China.

International Trading Office: A-4035 RuiFeng Business Expo , Wuhu City, China.

Web: www.mikrosize.com Email: mikrosize@mikrosize.com

