

MRocky-150/45A

Fully Automatic Full Rockwell Hardness Tester



Video



Contact us

Mikrosize Precision Instrument Co.,Ltd

A-4035 RuiFeng Business Expo, Wuhu City, China , 241000.

Web: www.mikrosize.com

Email: mikrosize@mikrosize.com



Features and Applications

Product Features

- Closed loop system, ready for use upon power-on.
- Adopts a novel head-down pressing structure with a fixed stage, eliminating coaxiality errors common in traditional screw types.
- Fully automatic operation: loading, dwell time, and unloading of test forces.
- High-precision guide rails control precise head movement.

High-definition LCD touch screen, clear display, simple and convenient operation.

High-precision displacement sensor, hardness resolution up to 0.1 HR.

Wide range of test scales: Rockwell, Plastic Rockwell, Superficial Rockwell.

Equipped with an external Bluetooth printer.

Hardness values for all scales can be calibrated.

USB and RS232 interfaces for computer connection.

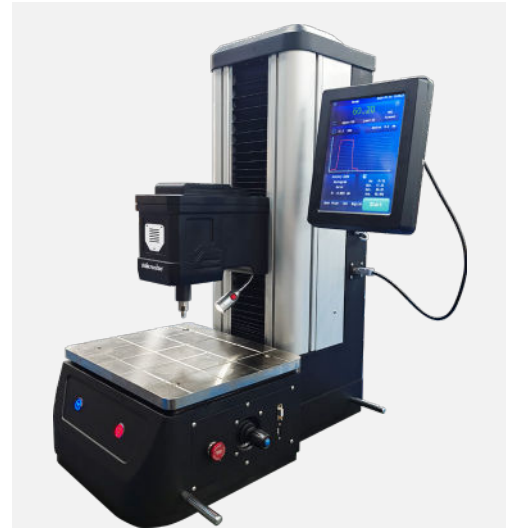

Product Applications

- Mechanical Manufacturing
- Used to test the hardness of various mechanical components to ensure product quality and performance.
- Aerospace
- Precisely measures material hardness, providing crucial data support for the design and manufacturing of aerospace vehicles.
- Metal Smelting & Processing
- Used for hardness testing of raw materials and finished products to evaluate their quality and performance.



Instrument Appearance

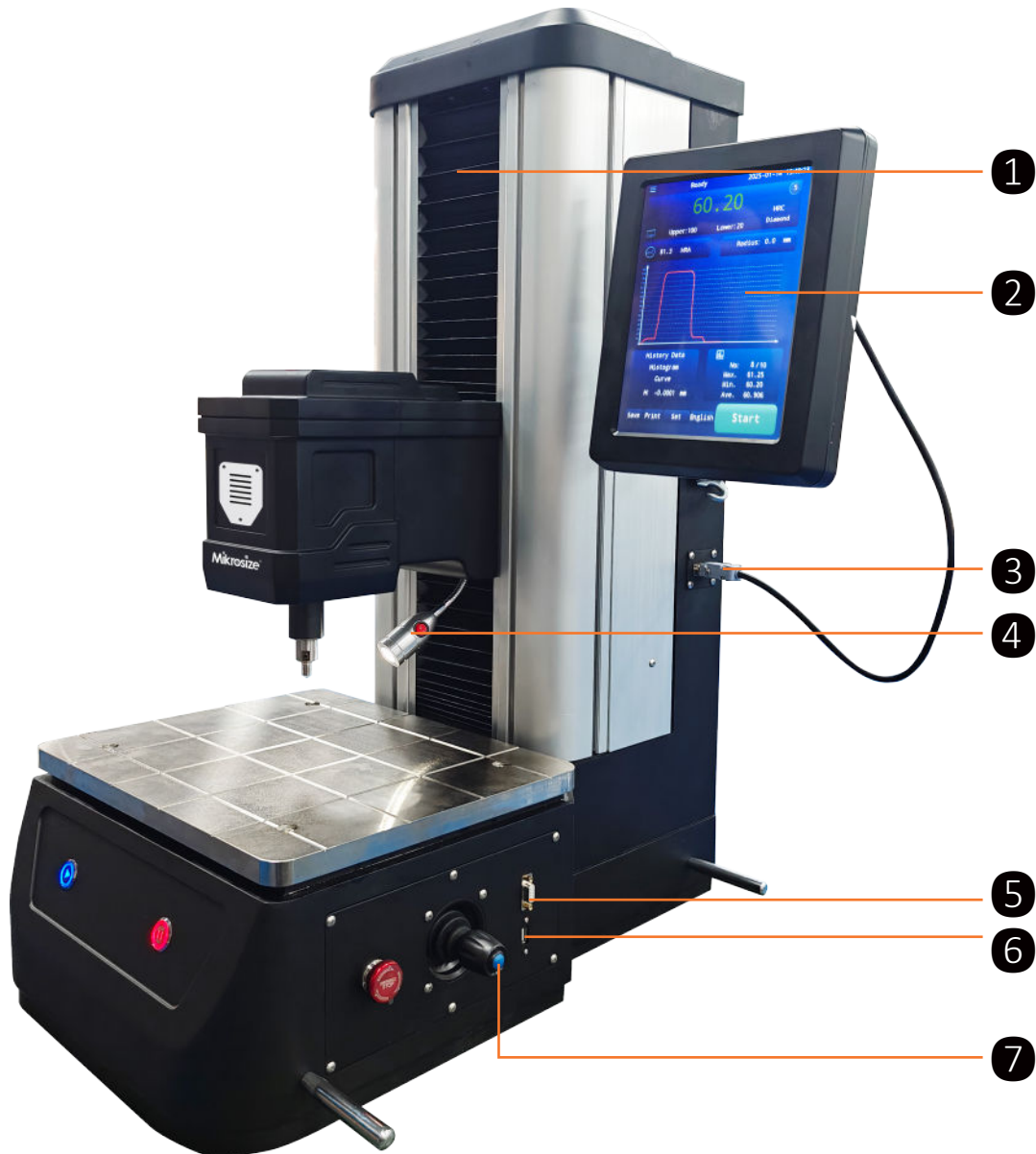

1. Guide Rails

4. Illumination Lamp

7. Control Joystick

2. Display Screen

5. RS232 Interface

3. Touch Screen Interface

6. USB Interface

Instrument Appearance

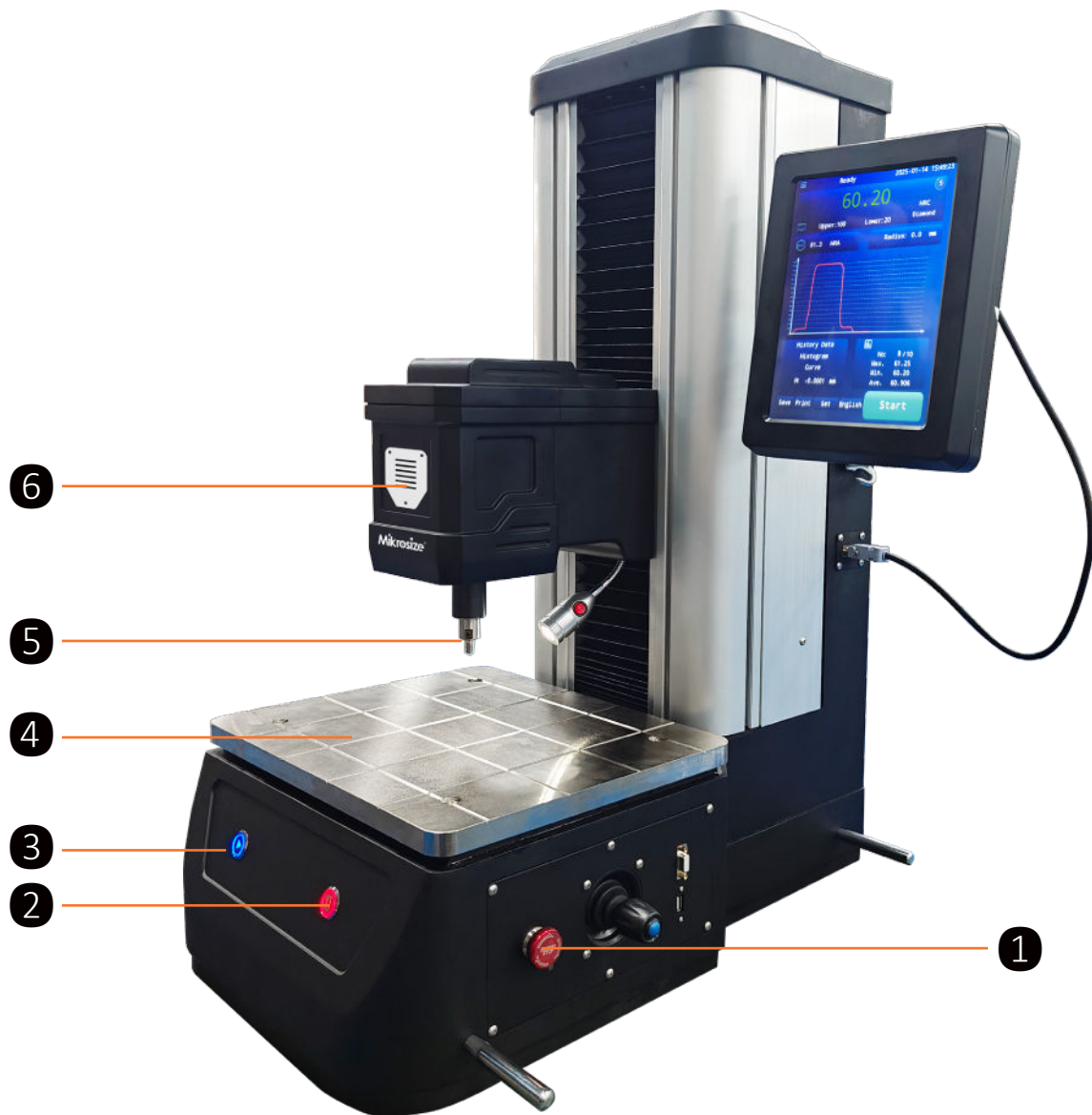

1. Emergency Stop Button

2. Stop Button

3. Start Button

4. Stage

5. Indenter

6. Downward Pressing Head

Instrument Appearance



1.Power Switch

2.Power Cord Interface

Product Details

Detail Display



- This equipment adopts a head-down movable structure, with movement controlled by high-precision guide rails.
- This method eliminates coaxiality errors generated by traditional lead screws, improves testing accuracy, and enhances the stability of the hardness tester.

Settings / Bluetooth Printer

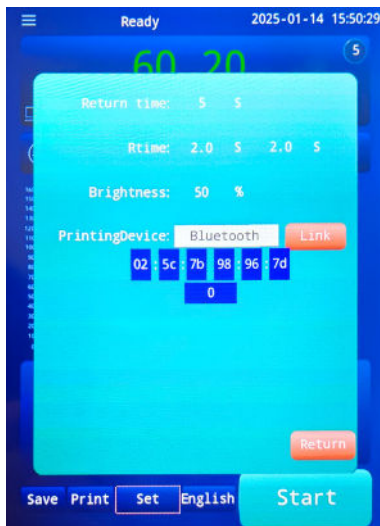

Settings



Bluetooth Printer

- The device has built-in Bluetooth functionality. When paired with a wireless printer, test results can be printed conveniently and promptly.

Operation Interface

Main Interface

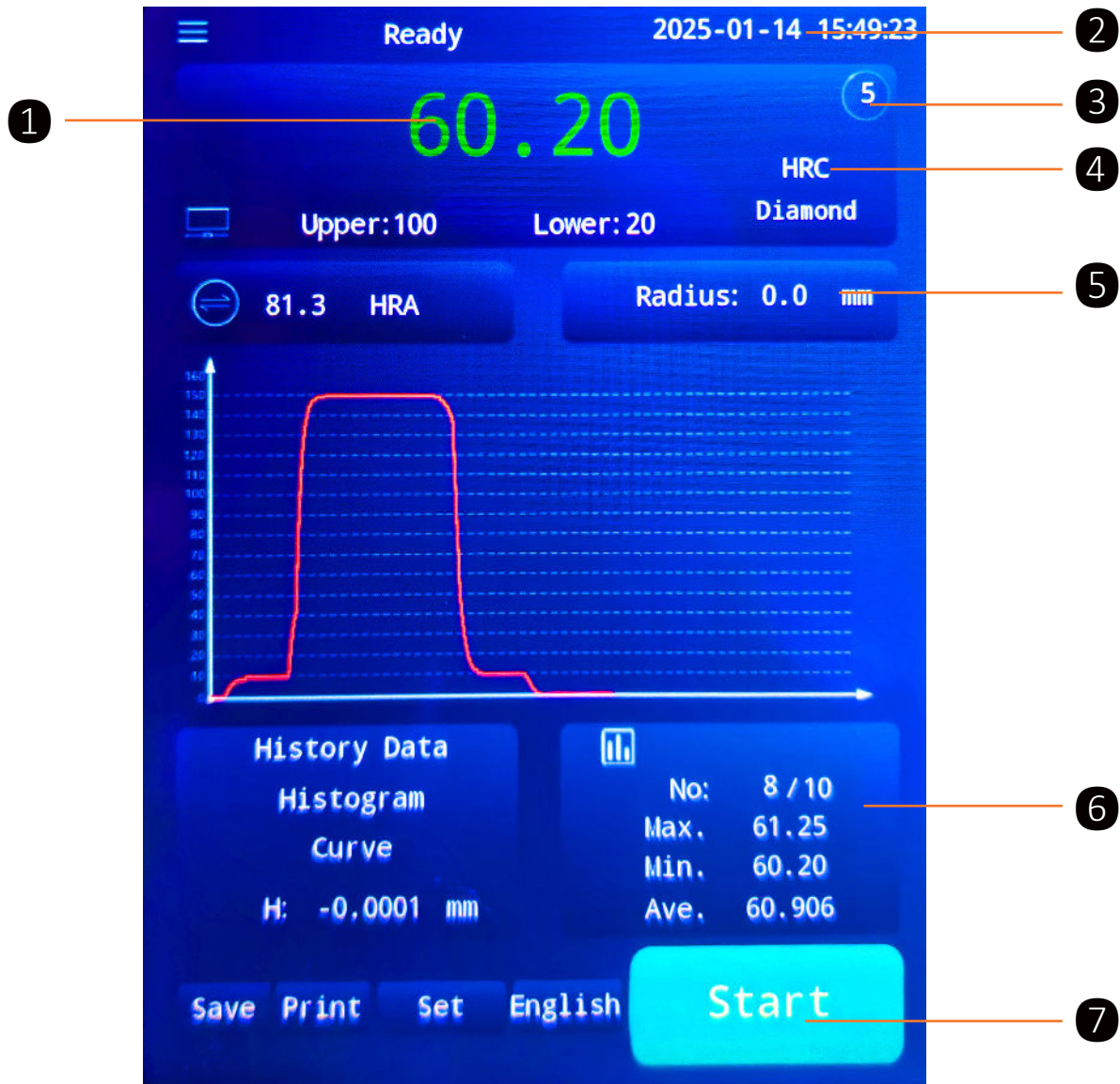

1. Test Result

2. Date & Time

3. Dwell Time

4. Test Scale

5. Curvature Correction

6. Test Data

Operation Interface

Main Interface

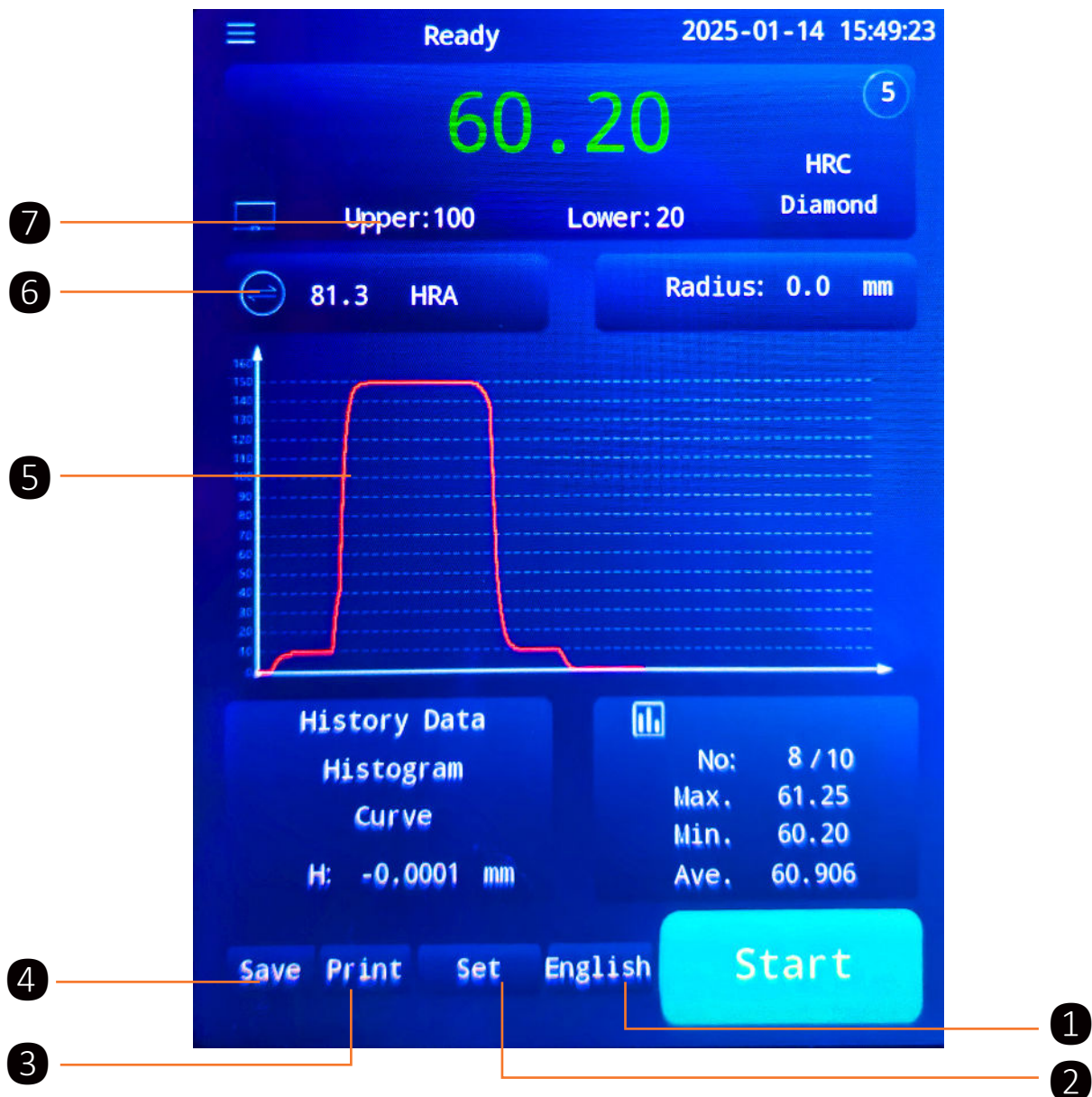

1. Language Switch

2. Settings Button

3. Print Button

4. Save Button

5. Real-time Force Curve

6. Scale Conversion

7. Upper/Lower Limits

Operation Interface

Scale Selection

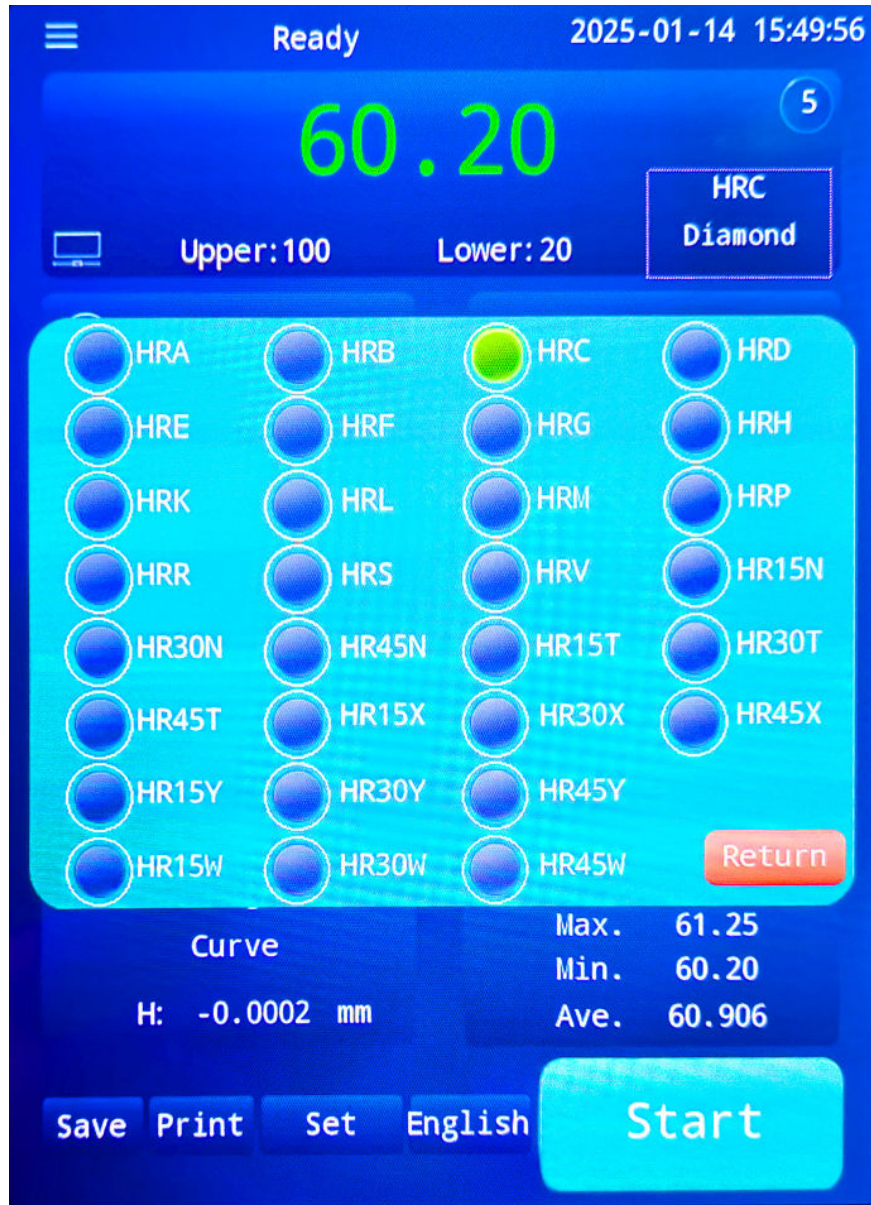

- The device covers standard Rockwell scales, Plastic Rockwell scales, and Superficial Rockwell scales, offering a total of 30 selectable test scales:

HRA, HRB, HRC, HRD, HRE, HRF, HRG, HRH, HRK, HRL, HRM, HRP, HRR, HRS, HRV, HR15N, HR30N, HR45N, HR15T, HR30T, HR45T, HR15X, HR30X, HR45X, HR15Y, HR30Y, HR45Y, HR15W, HR30W, HR45W

Operation Interface

Scale Conversion

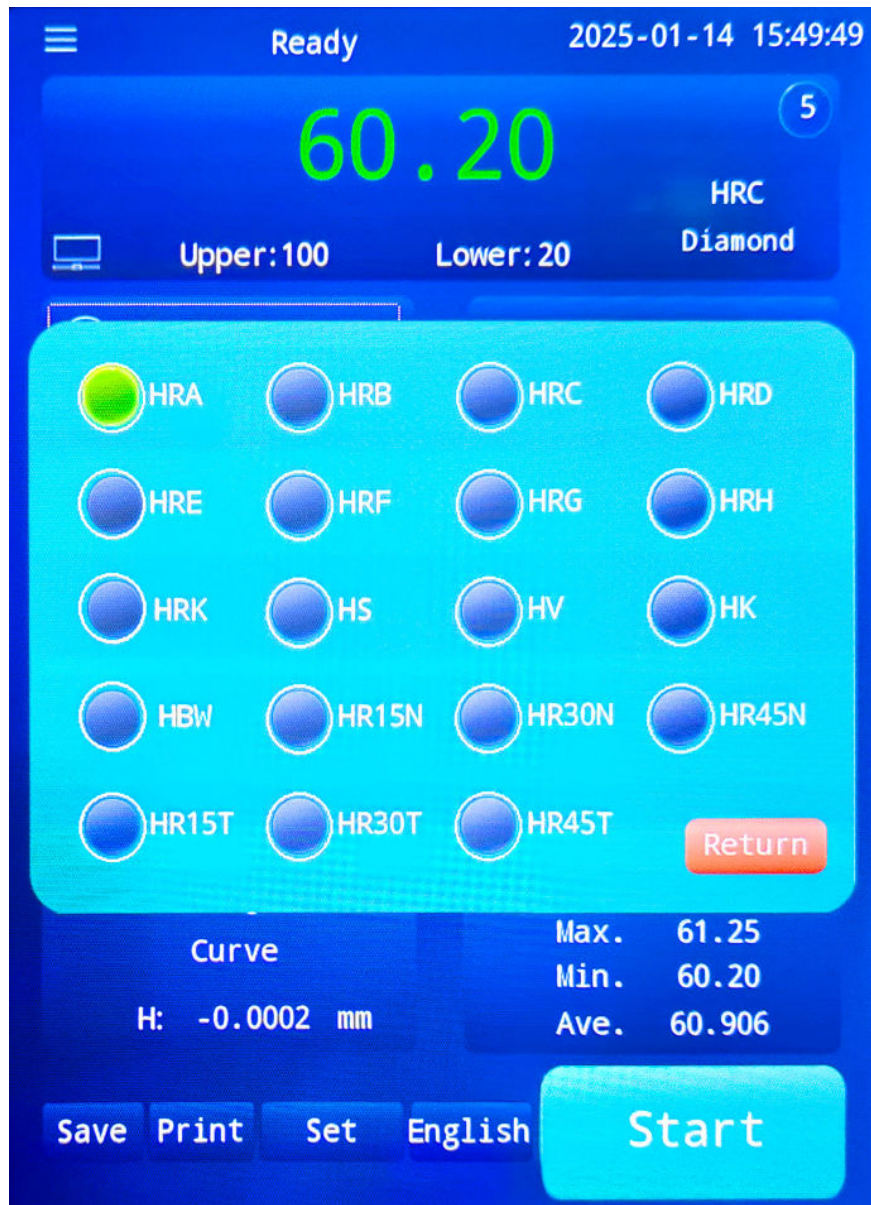

- After testing, hardness values can be converted to values of other hardness scales. The device supports conversion to 19 common hardness scales, including Vickers hardness, Brinell hardness, Knoop hardness, etc.

HRA、HRB、HRC、HRD、HRE、HRF、HRG、HRH、HRK、HS、HV、HK、HBW、HR15N、HR30N、HR45N、HR15T、HR30T、HR45T

Operation Interface

Test Data



- Up to 10 sets of data can be recorded in a single test session
- Automatically calculates maximum, minimum, and average values.
- Click the Save button after testing to save results to Historical Data

Operation Interface

Historical Data



- Search data
- Delete data
- Print data output

Operation Interface

Data Processing

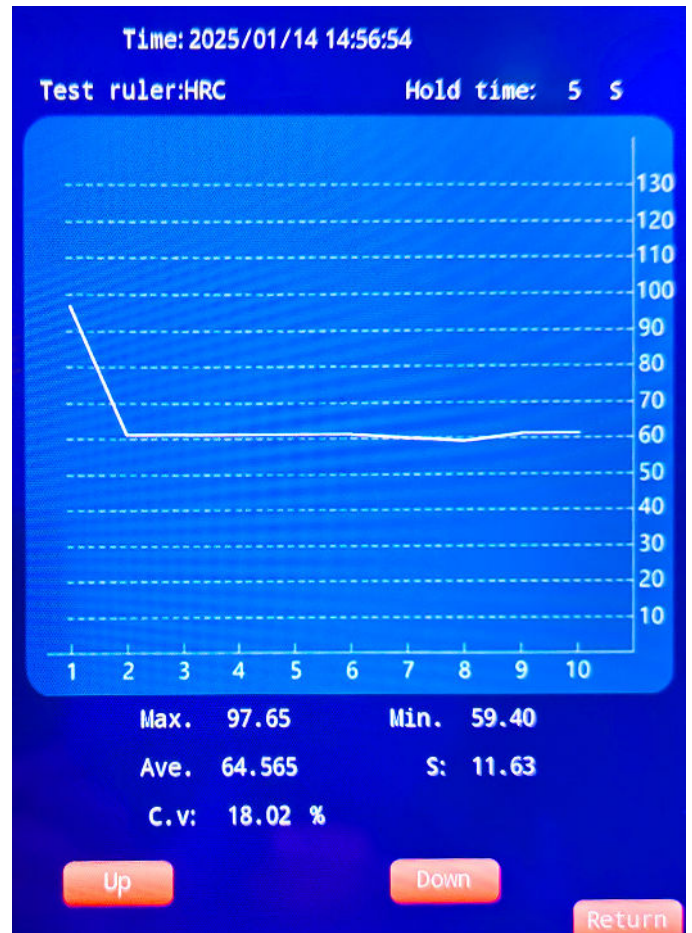
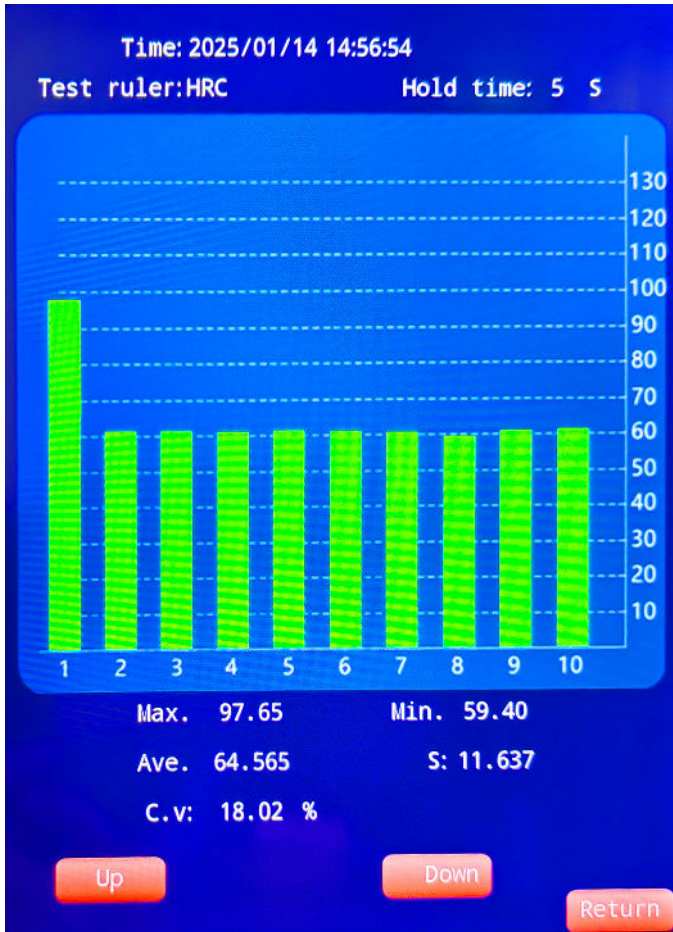

- Test data is processed and presented in the form of bar charts and curve graphs, making results more intuitive.

Operation Interface

Settings

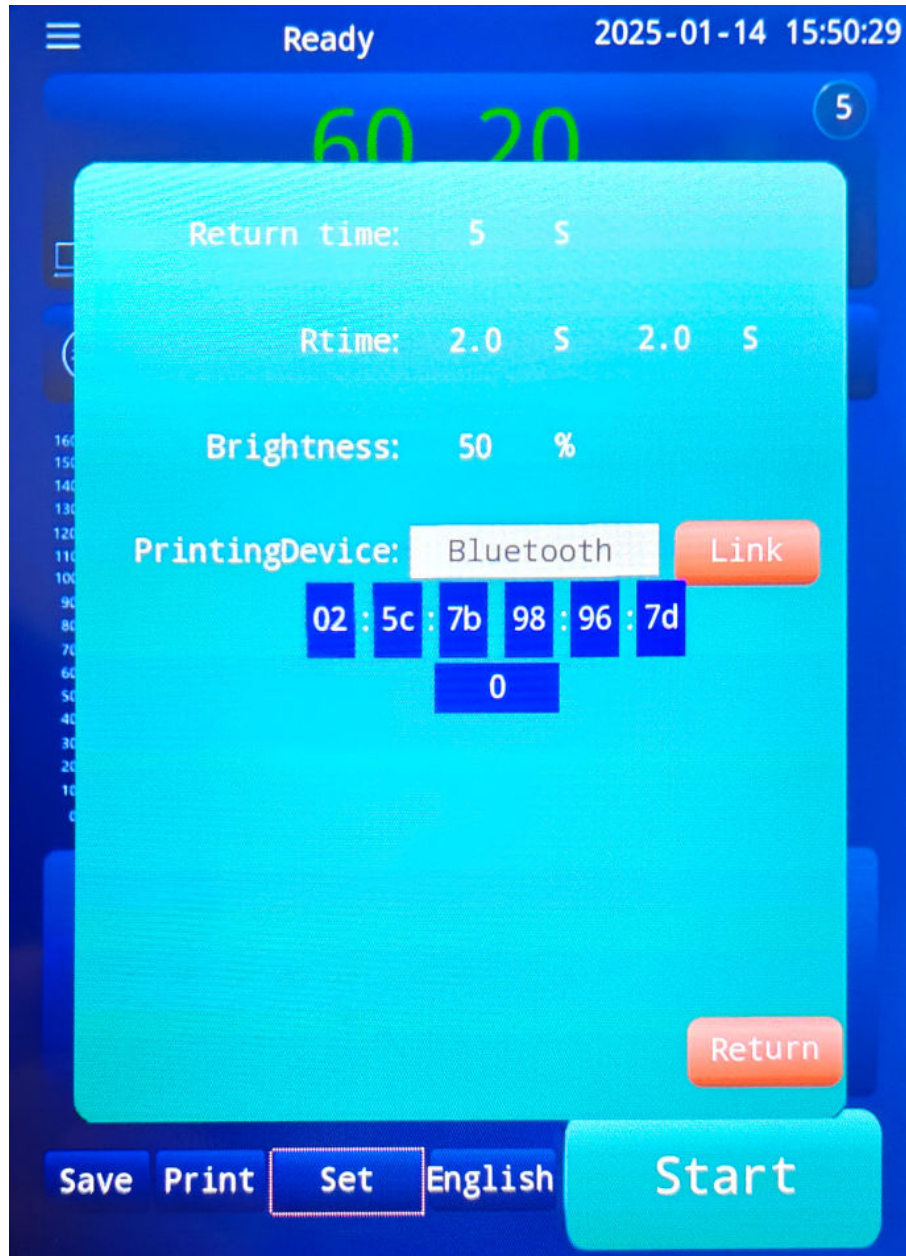

- Adjust dwell time
- Adjust screen brightness
- Connect Bluetooth printer

Operation Interface

Calibration

Ready 2025-01-14 15:50:52

60.20

5

HRC

Diamond

Upper: 100 Lower: 20

Hardness: HRC

	High	Median	Low
Standard	100.00	100.00	100.00
Measured	100.00	100.00	100.00

Return

Curve

H: -0.0003 mm

Max. 61.25
Min. 60.20
Ave. 60.906

Save Print Set English Start

- If test results are inaccurate, the software can be used to calibrate/correct the results.

Operation Interface

Language Selection

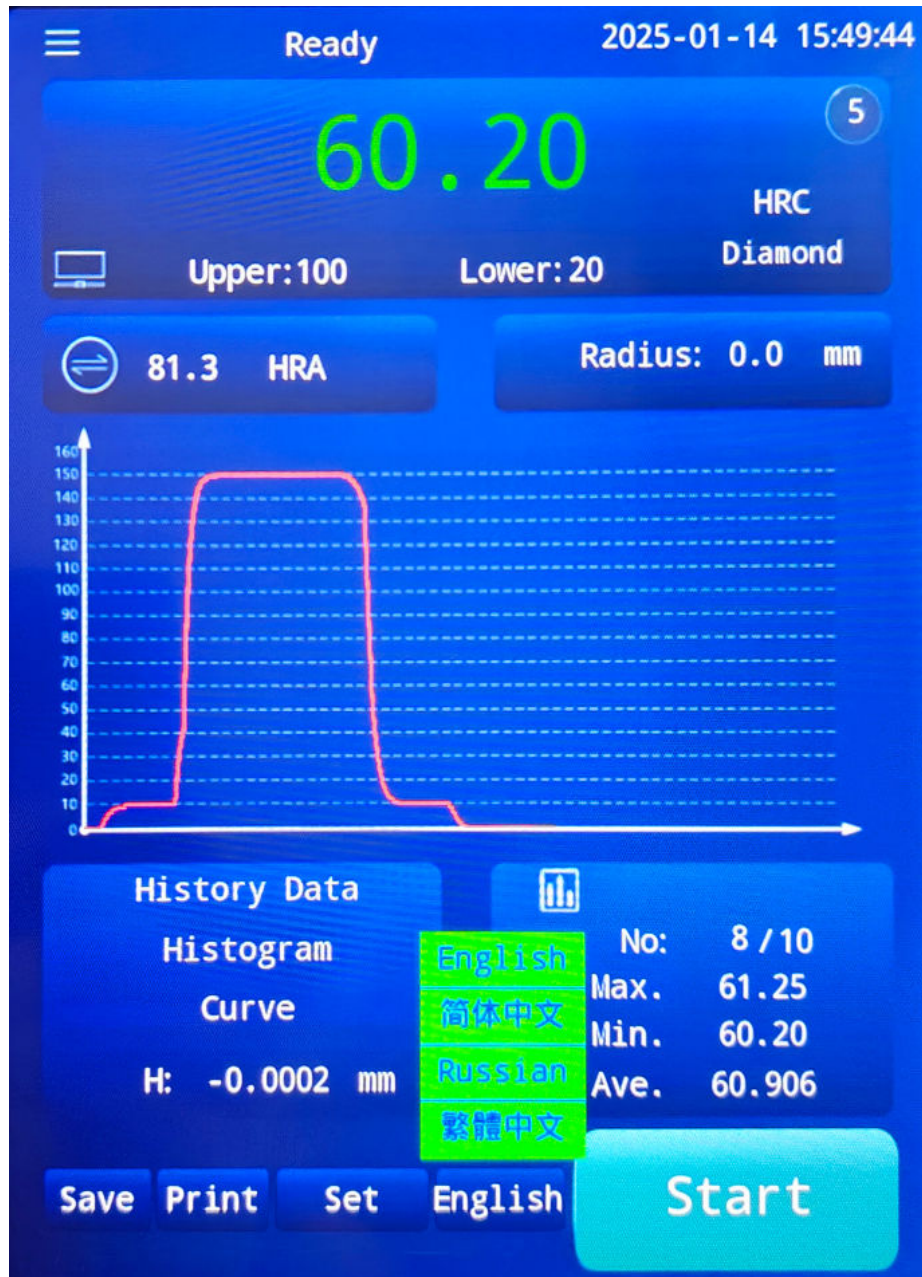

- Supports 4 display languages; other languages can be customized.

Instrument Dimension

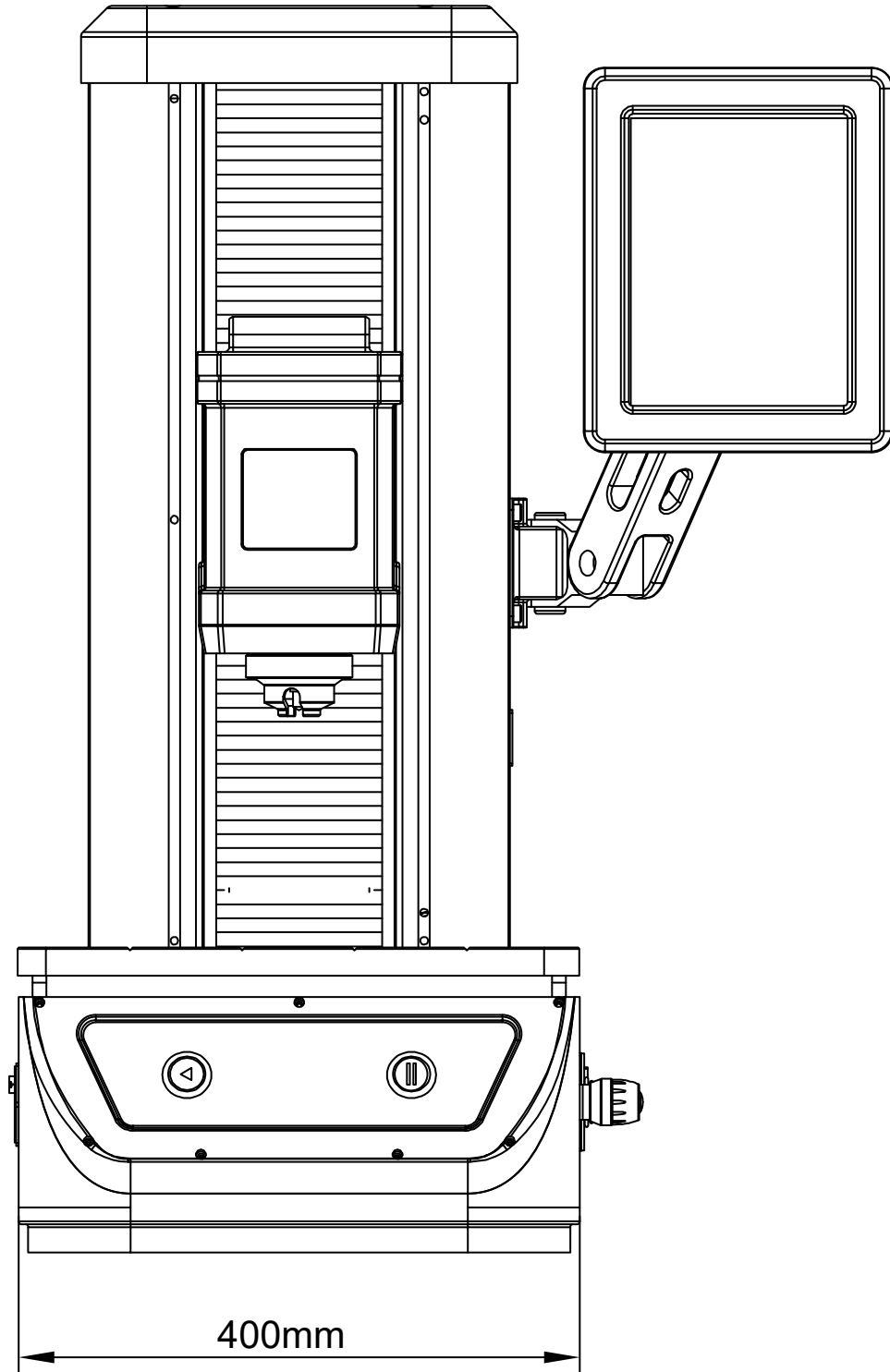

Instrument Dimension

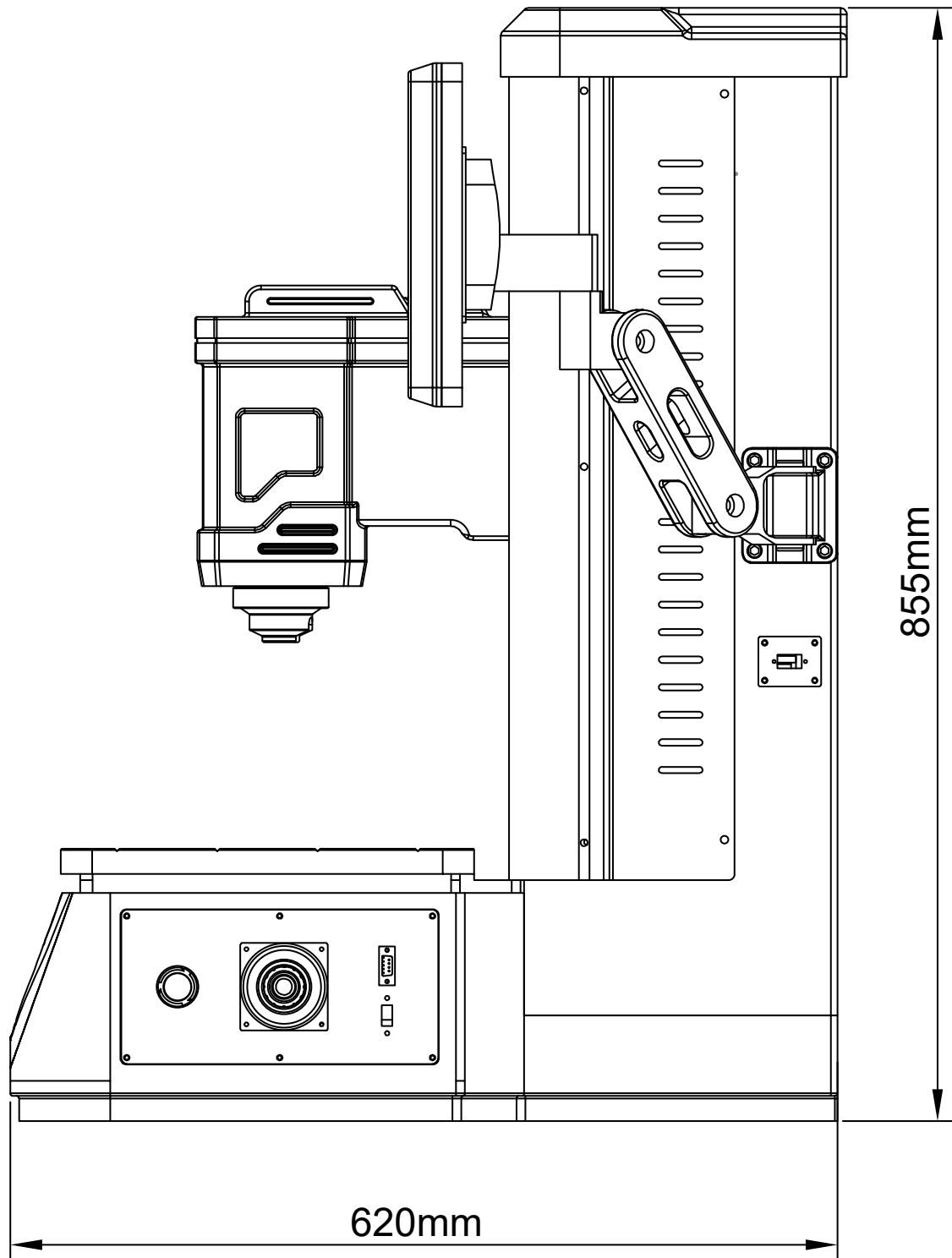

Technical Specification

Name	Fully Automatic Rockwell Hardness Tester
Model	MRocky-150/45A
Control System	Precision Stepper Motor Control System
Dwell Time	1~60s
Initial Test Force	10kgf (98.07N) 3kgf (29.4N)
Total Test Force	60、100、150kgf (588.4、980.7、1471N) 15、30、45kgf (47.1、294.2、441.3N)
Indenter Specification	Diamond Rockwell Indenter; Φ 1.5875mm Ball Indenter
Test Height	280mm







Technical Specification

Test Throat	170mm
Measurement Scales	HRA、HRB、HRC、HRD、HRE、HRF、HRG、HRH、HRK、HRL、HRM、HRP、HRR、HRS、HRV、HR15N、HR30N、HR45N、HR15T、HR30T、HR45T、HR15X、HR30X、HR45X、HR15Y、HR30Y、HR45Y、HR15W、HR30W、HR45W
Conversion Scales	HRA、HRB、HRC、HRD、HRE、HRF、HRG、HRH、HRK、HS、HV、HK、HBW、HR15N、HR30N、HR45N、HR15T、HR30T、HR45T
Hardness Resolution	0.1HR
Data Output	Bluetooth; RS232 Interface; USB Interface
Power Supply	AC220V, 50Hz
Dimensions (LxWxH)	400*855*620mm
Net Weight	Approx. 180kg

Standard Delivery

Name	Qty	Photo
Machine Mainframe	1 pc	
Diamond Rockwell Indenter	1 pc	
Φ1.5875mm Carbide Ball	1 pc	
Indenter	1 pc	
Φ1.588mm Carbide Ball	1 pc	
Φ100mm Flat Test Anvil	1 pc	
90*110mm V-shape Test Anvil	1 pc	

Standard Delivery

Name	Qty	Photo
Hardness Block (HRA)	1 pc	
Hardness Block (HRB)	1 pc	
Hardness Block (HRC)	3 pcs	
Hardness Block (HR15N)	1 pc	
Hardness Block (HR30N)	2 pcs	
Hardness Block (HR30T)	1 pc	
Bluetooth Printer	1 pc	

Standard Delivery

Name	Qty	Photo
Spirit Level	1 pc	/
Leveling Screws	4 pcs	/
65mm65mm Screwdriver	1 pc	/
Power Cord	1 pc	/
2A Fuse	2 pcs	/
Anti-dust Cover	1 pc	/
User Manual (incl. Certificate, Packing List)	1 pc	/

Optional Delivery

Optional Accessories

Carbide Balls

Various Stages

Various Hardness Blocks

Internal Machine Parts

Various Indenter

Mikrosize Precision Instrument Co.,Ltd

Add: A-4035 RuiFeng Business Expo , Wuhu City, China , 241000.

Tel: 0553-2836939 Fax:0553-2836938 Web: www.mikrosize.com

