



uRocky-150/45A Digital Twin Rockwell Hardness Tester

Instruction Manual



Anhui Mikrosize Precision Instrument Co.,Ltd

Add: A-4035 RuiFeng Business Expo, Wuhu City, China, 241000.

Web: www.mikrosize.com **Email:** mikrosize@mikrosize.com

Contents

1.Introduction
2.Technical specifications of the harness tester
3.Installation the of the hardness tester
4.Introductions to the functions of key board
5.Correct usage of the hardness tester
6.Maintenance and precautions
7.Accessories (Packing list)

1.Introduction

Automatic Rockwell hardness tester adopts large sized LCD screen, control panel adopts menu structure, has a good reliability, operability and intuitive.

Features:

- 1.Touch screen interface, easy to operate
- 2.Ready to work immediately, no need to install weights and run trial
- 3.Electric loaded,closed-loop control;
- 4.Rockwell hardness scales, 15 in total 15 kinds of Rockwell scales:
HRA HRB HRC HRD HRE HRF HRG HRH HRK HRL HRM HRP HRR HRS HRV
5. Hints for indenters when the scale is selected
6. Automatically apply initial and main pressures
7. High, medium, low three sections of hardness values can be automatically corrected
8. Automatic correction of test force. Accuracy raised for an order of magnitude.
9. Password to be set to protect the settings
10. More specimen and test information
- 11.Export the test data as EXCEL files in USB flash disk
12. Modular deigned, easy for maintenance.



2.The technical specifications of the hardness tester

1.Initial test force: Rockwell:10kgf (98.07N) superficial Rockwell:3kgf(29.4N)

tolerance: $\pm 2.0\%$

2.Total test force: Rockwell: 60kgf (588.4N)、 100kgf (980.7N)、 150kgf (1471N)

superficial Rockwell: 15kgf(147.1N)、 30kgf (294.2N)、 45kgf (441.3N)

Tolerance: $\pm 1.0\%$

3.Power source: AC220V $\pm 5\%$,50~60Hz

4.Time delayed control: 1~60s adjustable

5.Max height of specimen: 280mm

6.The Distance from the Indenter Central Point to the Instrument Body: 200mm

7.Total size(L×W×H)560×250×800(mm)

8.Total weight: 80kg

9.The Scales, Indenters, Test Force and Application Fields of the Rockwell Hardness Tester (Table 1)

10.The Scales, Indenters, Test Force and Application Fields of the superficial Rockwell Hardness Tester (Table 2)

11.Scales, hardness range of the Standard blocks, max. tolerance of displaying value of Rockwell.(Table 3)

12.Scales, hardness range of the Standard blocks, max. tolerance of displaying value of Superficial Rockwell.(Table 4)

13.Scales, hardness range of the Standard blocks, max. tolerance of displaying value, repeated deviations of Plastic Rockwell.(Table 5)

2.The technical specifications of the hardness tester

Table.1

Scales	Indenter	Initial test force	Total test force	Applications
HRA	Diamond indente	98.07 N (10kg)	60kgf(588.4N)	Hard alloy, carbide surface quenched steel, carburized steel plate(sheet)
HRD			100kgf(980.7N)	Steel sheet, surface quenched steel
HRC			150kgf(1471N)	Quenched steel tempered steel hard cast iron
HRF	Ball indenter φ1.5875mm (1/16 inch)		60kgf(588.4N)	Cast iron aluminum magnesium alloy bearing alloy annealed copper alloy mild steel sheet
HRB			100kgf(980.7N)	Mild steel aluminum alloy copper alloy malleable cast iron annealed steel
HRG			150kgf(1471N)	Phosphoresced bronze beryllium bronze malleable cast iron
HRH	Ball indenter φ3.175mm (1/8 inch)		60kgf(588.4N)	Aluminum zinc lead etc.
HRE			100kgf(980.7N)	Bearing alloy tin hard plastics and other soft materials
HRK			150kgf(1471N)	
HRL	Ball indenter φ6.35mm (1/4 inch)		60kgf(588.4N)	hard plastics,hard rubber,Aluminum ,surname,copper,Mild steel,plastic resin, fricative materials
HRM			100kgf(980.7N)	
HRP			150kgf(1471N)	
HRR	Ball indenter φ12.7mm (1/2 inch)		60kgf(588.4N)	
HRS			100kgf(980.7N)	
HRV			150kgf(1471N)	

2.The technical specifications of the hardness tester

Table.2

Scales	indenter	Initial test force	Total test force	Applications
HR15N	Diamond indenter cone angle: 120°radius of the sphere: 0.2mm	3kgf (29.42N)	15kg f (147.1N)	Nitrating steel, sheet steel, knife and other parts edges
HR30N			30kg f (294.2N)	
HR45N			45kgf (441.3N)	
HR15T	Ball indenter φ1.5875mm(1/16 inch)		15kg f (147.1N)	Mild steel, brass, bronze, aluminum alloys
HR30T			30kgf (294.2N)	
HR45T			45kgf (441.3N)	

Table.3

Scales	Hardness range of the Standard blocks	Max. tolerance of displaying value
HRA	(20~75)HRA	±2HRA
	(> 75 ~ 88)HRA	±1.5HRA
HRB	(20 ~ 45)HRB	±4HRB
	(> 45 ~ 80)HRB	±3HRB
	(> 80 ~ 100)HRB	±2HRB
HRC	(20 ~ 70)HRC	±1.5HRC
HRD	(40 ~ 70)HRD	±2HRD
	(58 ~ 69)HRE	±2..2HRE
HRE	(> 70 ~ 94)HRE	±2HRE
	(> 90 ~ 100)HRE	±2HRE
HRF	(60 ~ 90)HRF	±3HRF
	(> 90 ~ 100)HRF	±2HRF
HRG	(30 ~ 50)HRG	±6HRG
	(> 50 ~ 75)HRG	±4.5HRG
	(> 75 ~ 94)HRG	±3HRG
HRH	(80 ~ 100)HRH	±2HRH
HRK	(40 ~ 60)HRK	±4HRK
	(> 60 ~ 80)HRK	±3HRK
	(> 80 ~ 100)HRK	±2HRK
HRL	(100 ~ 120)HRL	±1.2HRL
HRM	(85 ~ 110)HRM	±1.5HRM
HRR	(114 ~ 125)HRR	±1.2HRR

2.The technical specifications of the hardness tester

Table.4

Scales	Hardness range of the Standard blocks	Max. tolerance of displaying value
15N	70~77 HR 15N 78~88 HR 15N 89~91 HR 15N	±2 HRN
30N	42~54 HR 30N 55~73 HR 30N 74~80 HR 30N	
45N	20~31 HR 45N 32~61 HR 45N 63~70 HR 45N	
15T	73~80 HR 15T 81~87 HR 15T 88~93 HR 15T	±3 HRT
30T	43~56 HR 30T 57~69 HR 30T 70~82 HR 30T	
45T	12~33 HR 45T 34~54 HR 45T 55~72 HR 45T	

Table.5

Scales	Hardness range of the Standard blocks	Max. tolerance of displaying value	Repeated deviation is equal or lesser than
HRE	70~94HRE	±2.0HRE	2.5HRE
HRL	100~120HRL	±1.2HRL	1.5HRL
HRM	85~110HRM	±1.5HRM	2.0HRM
HRR	114~125HRR	±1.2HRR	1.5HRR

3.Installation Of The Hardness Tester

1.The working condition of the tester

- 1.1 Under the ambient temperature, i.e. between 10~30°C;
- 1.2 The relative humidity in the test room shall not be over 65%;
- 1.3 In an environment free from vibration and without corrosive in surroundings.

2.The unpacking of the tester

- 2.1 Remove the outer box, left and move the box and take out the accessories kit.
- 2.2 Lift the bottom plate; unscrew the two M10 bolts under the bottom plate with a spanner, to separate the hardness tester from the bottom plate, take out the hardness tester (be careful).
- 2.3 After unpacking, the tester shall be placed on a stable bench with horizontal deviation less than 1mm/m. A hole shall be drilled at an appropriate location on the bench (see Fig.1) to enable the up and down moving shaft to operate properly.

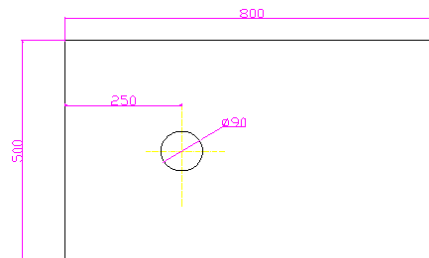

(Fig1)

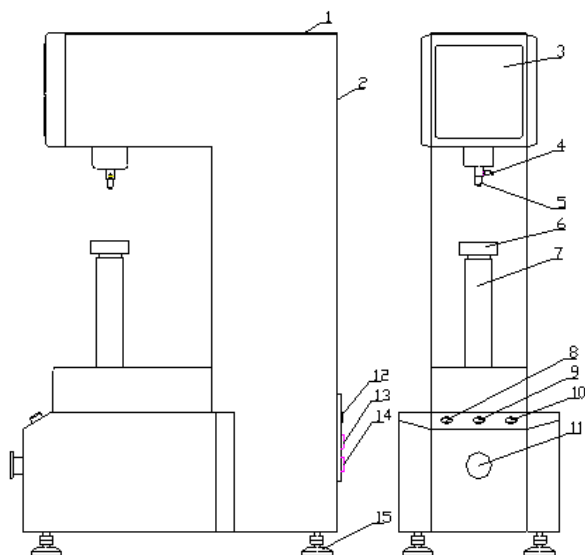

- 1-roof cover
- 2-back cover
- 3-screen
- 4-indenter screw
- 5-indenter
- 6-working table
- 7-lead screw
- 8-decline button
- 9-load button
- 10-rose button
- 11-scram
- 12-power switch
- 13-232port
- 14-USB socket
- 15-level adjustment screw

4.Introduction To The Keyboard Functions

4.1 Plug in the socket,insert the USB flash disk,turn on the boat-shaped switcher, the main screen lights. Attention: when the tester is turned on, it will begin initializing. You can not operate it until initialization is over.

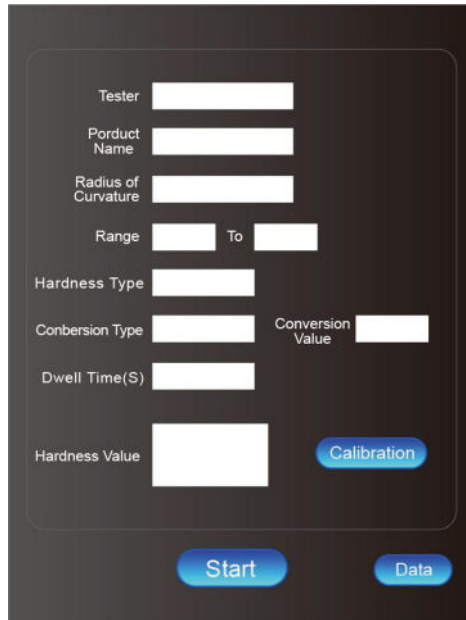
The image shows a dark-themed software interface for a hardness tester. It features several white text input fields arranged vertically: 'Tester', 'Product Name', 'Radius of Curvature', 'Range' (with 'To' between two smaller input boxes), 'Hardness Type', 'Conversion Type', 'Dwell Time(S)', and 'Hardness Value'. To the right of the 'Conversion Type' field is a 'Conversion Value' field. At the bottom of the input area is a 'Calibration' button. Below the main input area are two larger buttons: 'Start' and 'Data'.

(Fig. 2)

“operator, sample, range, load, dwell time, conversion” Textboxes beside these words are used to enter the information.

4.2 information entry

4.2.1 Entry of operator and sample name.

Click the to the right side of Operator and Sample,enter the names respectively by the keyboard, then click OK to confirm. You can also click the ESC to return if you don't need to change the existing names. As Fig.3



(Fig. 3)

4.Introduction To The Keyboard Functions

4.2.2 Entry of range and dwell time

Click the to the right side of Operator and Sample, enter the numbers respectively by the keyboard, then click OK to confirm. Click ESC to return (Fig.4)



(Fig. 4)

4.2.3 Choose the type of hardness. Click to the right of force and diameter. Then choose the type of hardness scale on the scale interface. If there is no need to change, click at the bottom to return to main interface. Scales available is shown as Fig.5

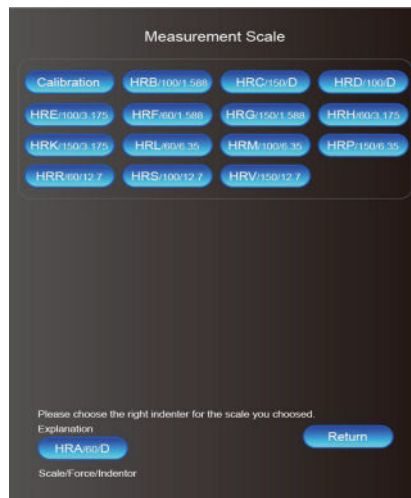

(Fig.5)

4.2.4 Click conversion then choose the type of scale. If there is no need for changing, click to return to main interface. Scales available is shown as Fig. 6

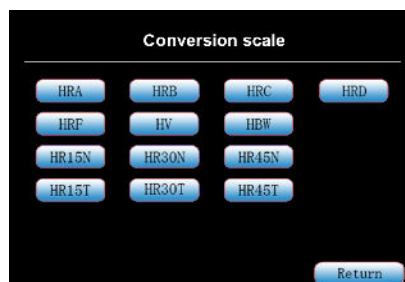

(Fig.6)

5.The Usage Of The Hardness Tester

1.Do all the preparatory work before the use

1.1 The surface of the specimen should be smooth and clean without any oxidized peels and concaves, dirty things and outstanding processing signs. The supporting plane of specimen and the working table should be clean to assure good tight between them.

1.2 The Min. thickness of the specimen should be 10 times superior to the depth of the indentation. After the test, the back of the specimen should not have any visible signs of deformation.

1.3 the specimen should be stably fixed on the working table. There should be no any movement of the specimen during the loading of test force and the test force should be loaded perpendicularly on the specimen.

1.4 the working table should be chosen according to the shape and size of the specimen. If the specimen has an irregular shape, a special holder should be made in accordance with the particular geometrical shape to make the value correct.

2.The Operation Procedure of the Hardness Tester

2.1 According to the extent of soft and hard of standard block, select scales According to Table.1 to select indenter according to scales.

For example to test the hardness of HRC:

2.1.1 Put the indenter (5) into the hole of main spindle closely against the supporting plane and make the caved plane of the indenter handle face the screw. Fasten slightly the indenter screw (4).

2.1.2 Open the power socket, press "SET", move cursor to HRC, press "OK", the screen gets to the required operating interface.

2.1.3 Fix the working table(6), put the specimen on the working table, push rose button to lift up the working table (6) slowly. When the distance between the indenter and the

5.The Usage Of The Hardness Tester

surface of the specimen is less than 3mm, stop movement and press the button "STR". The hardness tester loads test force automatically. (process: load, dwell, unload, show hardness)

2.1.4 Change the specimen; press the button "STR" to do the next measurement. In accordance with requirements of the identification code, the first test don't remember, starting from the second record hardness value, need 3-5 times take its average.

3.Regulation of Hardness Displaying Value

The precision of the hardness displaying value of the hardness tester is just calibrated before the instrument is turned out of the factory. If a deviation is caused due to the transportation or according to the various requirements of the client, the hardness value may be revised by pressing input keys.

Click  on the main interface, the screen shown as Fig. 7

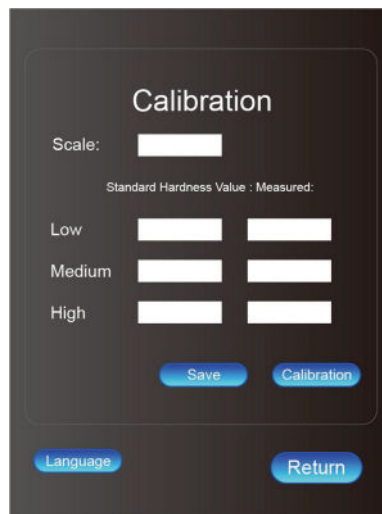

(Fig.7)

Place the standard hardness block on the testing table

- 1.Enter standard hardness value into box behind "standard hardness value"
- 2.Enter the same value into the box behind " measured hardness value"

Click "test" to measure the actual hardness value, if there is any deviation,enter the actual value into "measured hardness value" , then click "save".

If the force value is not accurate, click  to correct. Contact factory to guide.

6.Maintenance And The Precautions

- 1.The operator should observe the operation regulations and calibrate the instrument with the standard block before and after the test. If the tester is rarely used, the several tests should be carried out to make the tester stable and then carry out the necessary tests.
- 2.During the hardness test, when the loading and unloading of the test force or the keep of the dwell time is being carried out, it is prohibited to turning the load changing hand wheel.
- 3.The hardness block should be used only on the working plane with the distance of the two neighboring indentations and of the center of the indentations to their edges are not inferior 3mm. The life time of the blocks is 2 years.
- 4.During the transportation of the tester, the tester should be fixed with long poles, with the weights and the hanging rod discharged. Disconnect the power source before the weights and the hanging rod are taken out.
- 5.Keep the tester clean and cover the tester after the use, lubricate the hardness blocks and ball indenters with the grease.
- 6.Carry out periodic control of the tester, at least once a year in order to assure the correct operation of the tester.

7. Accessories(Packing list)

NO.	Name of Commodity (Standard)	Quantity
1	Diamond Rockwell Indenter	1
2	φ1.5875mm Ball Indenter	1
3	Testing Table (Big, Medium, "V")	3 in total
4	HRB	1
5	HRC(High, low)	1 each
6	HR15N、HR30N、HR30T	1 each
7	Fuse 2A	2
8	Power Cable	1
9	Plastic Anti-dust Bag	1
10	Instruction Manual	1
11	USB flash disk	1
12	Touch pen	1

Mikrosize Distributors Worldwide

Coventry,UK /Warsaw,Poland/Burago di Molgora, Italy/Langgöns,Germany/
Madrid, Spain/Istanbul,Turkey/Minsk,Belarus/Moscow , Russia /Sao Paulo, Brazil/
Mexico City ,Mexico/Penang, Malaysia/Bangkok Thailand etc.....



Anhui Mikrosize Precision Instrument Co.,Ltd

Factory Producing Add: N013 Shuiku Road Shatou, Changan Town, Dongguan, China.

International Trading Office: A-4035 RuiFeng Business Expo , Wuhu City, China.

Web: www.mikrosize.com Email: mikrosize@mikrosize.com

